

POTOMAC INSTRUMENTS INC.

INSTRUCTION MANUAL

TYPE 19 ANTENNA MONITOR SYSTEM

**POTOMAC INSTRUMENTS, inc.
932 PHILADELPHIA AVENUE
SILVER SPRING, MARYLAND 20910**



WARNING

This instrument must be used with a 3-prong U-grounded receptacle outlet. Failure to use a grounded outlet may result in improper operation or safety hazard.

INSTRUCTION MANUAL

TYPE 19 ANTENNA MONITOR SYSTEM

AM-19

RMP-19

Potomac Instruments, Inc.
932 Philadelphia Avenue
Silver Spring, Maryland 20910
(301) 589-2662

TABLE OF CONTENTS

<u>Paragraph</u>		<u>Page</u>
SECTION 1 GENERAL DESCRIPTION		
1.1	Scope of Manual	1-1
1.2	General Description	1-1
1.3	Summary of Specifications	1-5
SECTION 2 THEORY OF OPERATION		
2.1	AM-19 Antenna Monitor	2-1
SECTION 3 INSTALLATION AM-19		
3.1	Inspection	3-1
3.2	Monitor Configuration	3-1
3.3	Mounting and Power	3-2
3.4	Antenna Connections	3-2
3.5	Changing Reference Towers	3-4
3.6	Remote Control and Auxiliary Connections	3-6
SECTION 4 CALIBRATION AND OPERATION AM-19		
4.1	Calibration	4-1
4.2	Operation	4-3
4.3	Lightning and Overload Protection	4-5
4.4	Remote Control	4-5
SECTION 5 REMOTE METERING PANEL (s)		
5.1	Installation	5-1
5.2	Calibration	5-2
5.3	Operation	5-2
SECTION 6 PRECISION ANTENNA MONITOR PM-19 (s)		
6.1	Installation	6-1
6.2	Digital Voltmeter (DVM) Calibration	6-2
6.3	Symmetry Adjustments	6-2
6.4	Phase Calibration	6-3
6.5	Sense	6-4
6.6	Current Ratio Calibration	6-4

TABLE OF CONTENTS (continued)

<u>Paragraph</u>		<u>Page</u>
6.7	Current Deviation Calibration	6-5
6.8	Overload and Lightning Protection	6-8
6.9	Remote Control and Auxiliary Outputs	6-8
SECTION 7 DIGITAL REMOTE METERING PANEL RMP-19D		
7.1	Installation	7-1
7.2	Calibration	
7.3	Operation	
SECTION 8 REMOTE SWITCHING ADAPTER RSA-19 (s)		
8.1	Installation	8-1
8.2	Calibration	8-2
8.3	Operation	8-2
SECTION 9 MAINTENANCE		
9.1	General	9-1
9.2	Trouble Shooting	9-1
9.3	Power Supply	9-2
9.4	Relay Replacement	9-2
9.5	Phasing Capacitor Adjustment - Small Phase Errors	9-2
9.6	Servicing Input Modules	9-3
9.7	Replacing Current Detector Diode	9-3
9.8	Digital Voltmeter	9-3
SECTION 10 REPLACEABLE PARTS		
10.1	General	10-1
SECTION 11 SCHEMATIC DIAGRAMS		
SECTION 12 AM-19D(210)		

(s) The sections of this manual which deal exclusively with the details of a particular unit are included as supplements when the units are specified for a particular installation.

LIST OF TABLES

<u>Table</u>		<u>Page</u>
1-1	Summary of Outstanding Features	1-1
1-2	Performance Specifications, AM-19 Antenna Monitor	1-5
1-3	Performance Specifications, PM-19 Precision Monitor (AM-19 with PMA-19)	1-6
3-1	AM-19 Interface Connections	3-8
10-1	Index of Replaceable Parts	10-1

LIST OF FIGURES

<u>Figure</u>		<u>Page</u>
1-1	AM-19 Antenna Monitor Photograph	1-3
1-2	PM-19 Precision Monitor (AM-19 with PMA-19) Photo	1-3
1-3	RMP-19 Remote Metering Panel Photograph	1-4
1-4	RMP-19D Digital Remote Metering Panel Photograph	1-4
2-1	Phase Detector Response	2-3
11-1	AM-19, Simplified Schematic Diagram	11-2
11-2	AM-19, Main Chassis Schematic Diagram	11-3
11-3	AM-19 Input Module, Schematic Diagram	11-4
11-4	Limiter Module, Schematic Diagram	11-5
11-5	Phase Detector Module, Schematic Diagram	11-6
11-6	Current Meter Module, Schematic Diagram	11-7
11-7	Power Regulator Module, Schematic Diagram	11-8
11-9	PMA-19, Main Chassis Schematic Diagram	11-10
11-10	PMA-19 Input Module, Schematic Diagram	11-11
11-11	Current Deviation and Switching Module, Schematic	11-12
11-12	PMA-19, Analog Buffer Amp, Schematic Diagram	11-13
11-13	Remote Metering Panel, RMP-19, Schematic Diagram	11-14
11-14	Typical Remote Installation, Functional Diagram	11-15

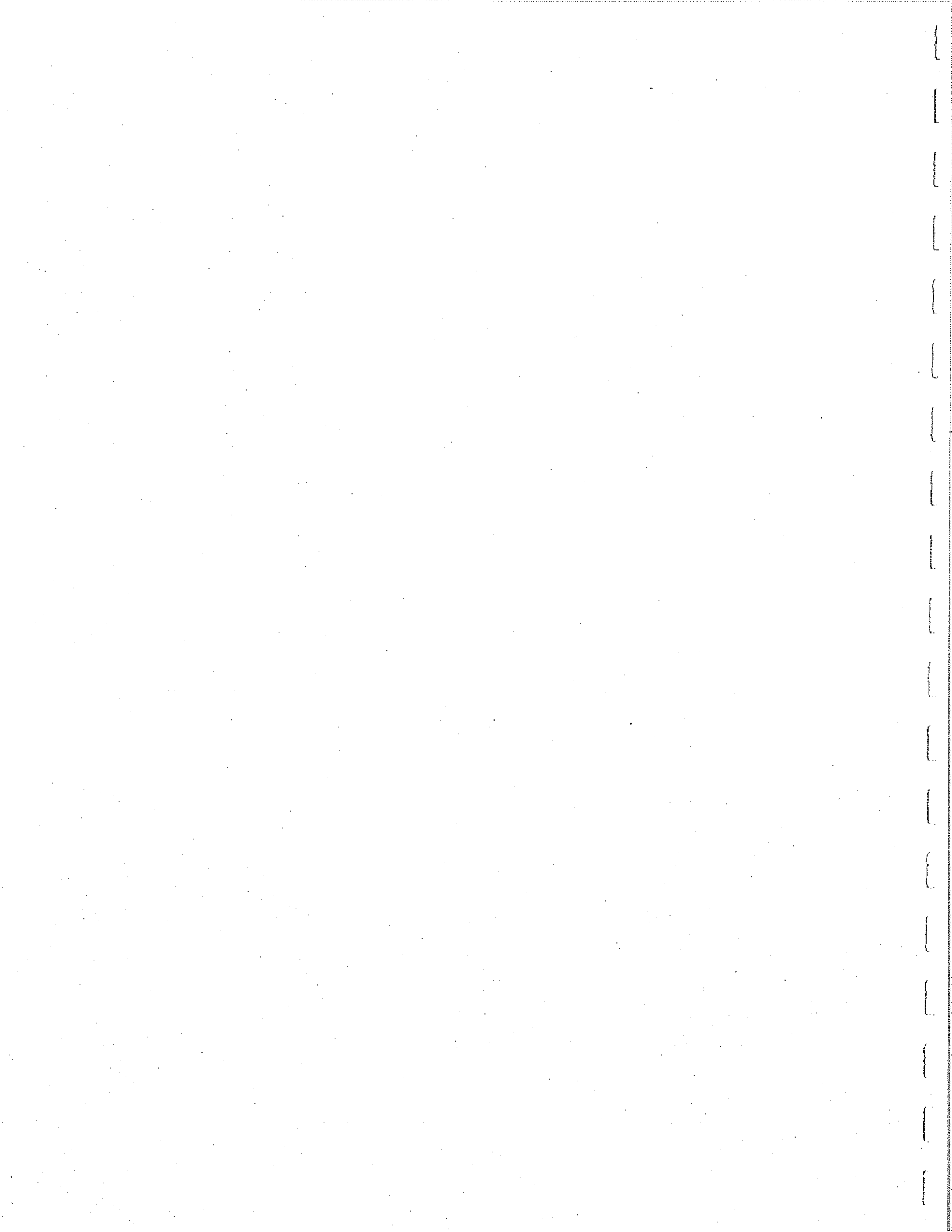

SECTION 1 GENERAL DESCRIPTION

1.1 Scope of Manual

This instruction manual covers the theory of operation, installation, operation and maintenance of the equipment comprising the Type 19 Antenna Monitor System.

The Type 19 System consists of the following major rack-mounted units which are connected in various combinations depending on requirements:

Antenna Monitor, AM-19(204)
Precision Monitor Adapter, PMA-19
Remote Metering Panel, RMP-19(204)
Digital Remote Metering Panel, RMP-19D(210)
Remote Switching Adapter, RSA-19

The sections of this manual which deal exclusively with the details of a particular unit are included as supplements when the units are specified for a particular installation.

1.2 General Description Type 19 System

1.2.1 Introduction

The Type 19 Antenna Monitor is designed to accurately measure the phase relationships and sampling loop currents within the directional antenna arrays of AM broadcast stations. The Potomac Instruments system offers a number of unique features not provided in previously available monitors. These features are summarized in table 1-1.

Table 1-1 Summary of Outstanding Features

1. Superior electrical performance with solid state design
2. Ultra reliable - mercury wetted relays and mil-type components
3. Digital display of all three precision monitor functions
4. No input adjustments - rated accuracy over full range of input level
5. Non sequencing "touch" operation provided with lighted push buttons
6. Interference filters as standard feature

7. Overload and lightning protection
8. Remote operation with serial digital and BCD output for printers
9. Standard configuration up to 12 towers DA-3
10. Compact building block system design

1.2.2 AM-19 (204)

The Antenna Monitor, Type AM-19 is the basic instrument for measuring phase and loop current, and provides power and most of the control functions for the other units of the system. The standard AM-19 is designed to monitor up to 12 towers and can accommodate DA-1 (DA-N), DA-2, and DA-3 antenna patterns. The unit includes two precision meters for a simultaneous indication of phase and current ratio. The phase meter is calibrated in degrees and indicates the phase difference between any selected tower and the reference tower corresponding to the pattern in use. The phase meter accuracy is ± 1.0 degrees with a resolution of 0.5 degrees. The current ratio meter is calibrated in percent of the reference tower loop current for any selected tower. The current ratio meter accuracy is ± 1.5 percent with a resolution of 0.5 percent.

For many applications, the AM-19 is the only Type 19 unit required.

1.2.3 PMA-19

Many of the more critical antenna arrays require phase and current resolutions of 0.1 degree and 0.1 percent respectively. To obtain this performance, the AM-19 is connected with the Precision Monitor Adapter, Type PMA-19. This unit includes a digital voltmeter and the critical circuitry and controls associated with the current deviation mode, and provides a 4 digit L.E.D. display of phase, current ratio, and current deviation.

Basically, the current deviation circuit consists of two current detectors, one connected to the reference tower sampling line, the other to a selected tower, with the detector outputs connected differentially to the digital voltmeter. Attenuators are provided to normalize the input level from each sampling line for a differential voltmeter indication of 000.0. The circuit constants are designed so that any variation of the sampling line input level is indicated directly on the DVM in percent of the normalized ratio. The "differential" approach to this measurement allows current ratio variations to be determined with a resolution of 0.1 percent, even in the presence of large carrier level variation due to asymmetrical modulation and other causes. The standard PMA-19 will accommodate up to 12 towers in a DA-1 or DA-2 pattern, and up to 6 towers in a DA-3 pattern. The AM-19 and PMA-19 units can be specified together as the Type PM-19 Precision Monitor.

1.2.4 RMP-19(204)

In remote control installations of the AM-19 Antenna Monitor, the Remote Metering Panel Type RMP-19 is provided at the studio to directly monitor phase and loop current. The RMP-19 meter physically duplicates the meters in the

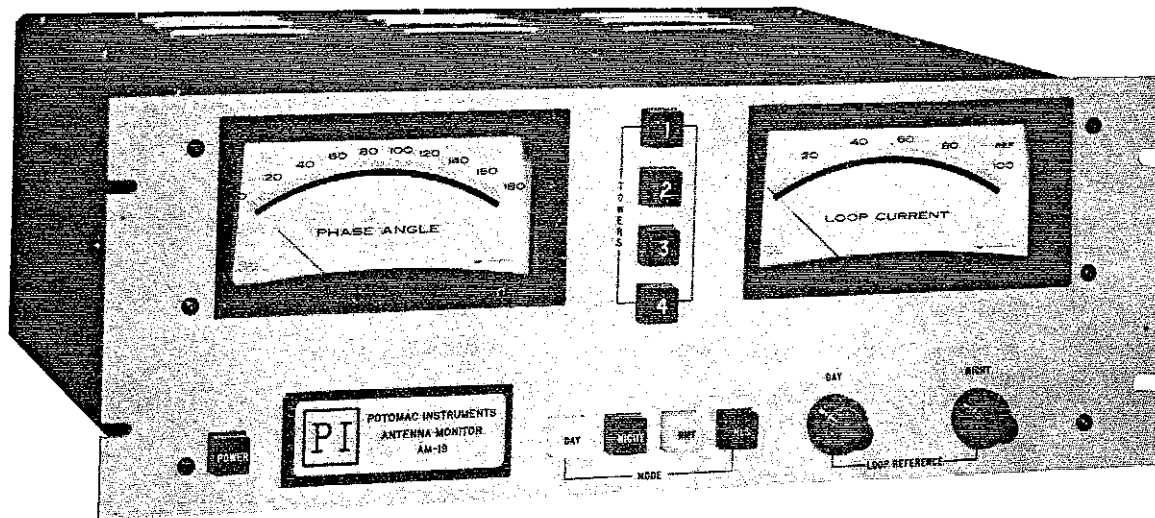

Figure 1-1. AM-19 Antenna Monitor

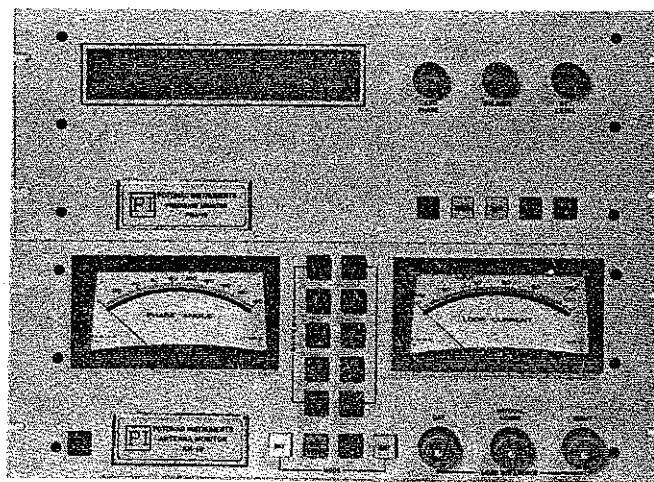

Figure 1-2. PM-19 Precision Monitor (AM-19 with PMA-19)

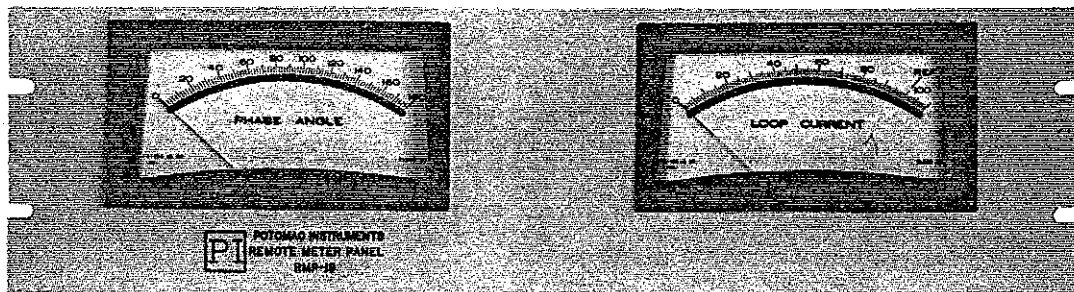

Figure 1-3. RMP-19 Remote Metering Panel

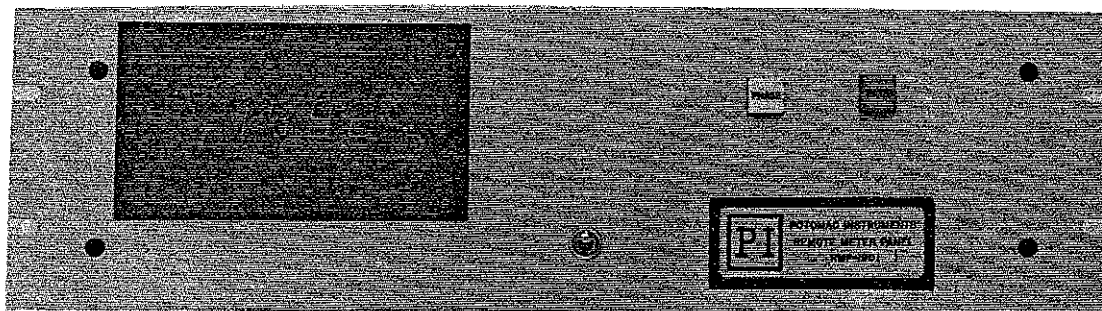

Figure 1-4. Digital Remote Metering Panel RMP-19D(210)

AM-19 and provides the same specified accuracy and resolution. A relay mounted behind the meter panel allows selection of either meter directly from the studio remote control unit as the phase angle and loop current functions are "dialed up".

Calibration controls for the RMP-19 are included in the AM-19 and the system is designed to provide specified accuracy over lines with up to 11,000 ohms resistance.

1.2.5 RMP-19D(210)

The Digital Remote Metering Panel RMP-19D is designed to provide a 4 digit L.E.D. display of the functional outputs of the AM-19 and the PM-19 Antenna Monitors. When used locally with the AM-19, the RMP-19D provides a greatly improved phase resolution of 0.1 degree, and the digital readout significantly reduces the possibility of operator error in recording phase and current ratio readings. However, because of normal carrier level fluctuations, the RMP-19D is not a substitute for the PMA-19 in providing a loop current resolution of 0.1 percent. The RMP-19D(210) can also be substituted for the RMP-19 Remote Metering Panel as the studio indicating device in remote control installations of the AM-19 and PM-19 monitors.

1.2.6 RSA-19

Remote operation of the Type 19 System requires that the tower and mode selector relays be energized from the transmitter remote control unit. In some systems the "raise-lower" control circuits do not utilize voltages which are compatible with the Type 19 monitor, and in these installations the Remote Switching Adapter Type RSA-19 will be required. This unit provides all the necessary relays with correct coil voltage and contacts to properly interface the Type 19 monitor with the remote control equipment. Power for the RSA-19 is provided from the AM-19. Because of the diversity of remote control systems used for broadcast applications, the Remote Switching Adaptors are custom designed for each installation.

1.3 Summary of Specifications

Table 1-2 Performance Specifications, AM-19 Antenna Monitor

Frequency Range:	150 KHz to 2000 KHz
Phase Angle Range:	0 to 180 degrees, lead or lag
Phase Accuracy:	± 1.0 degree
Phase Resolution:	0.5 degree
Current Ratio Accuracy:	$\pm 1.0\%$ (20% to 110%)
Current Ratio Resolution:	0.5%

Table 1-2 Performance Specifications, AM-19 Antenna Monitor (continued)

Metering Tracking Accuracy:	$\pm 0.5\%$
Available Patterns:	DA-1 (or DA-N), DA-2, DA-3
Maximum Towers:	12
RF Input Impedance:	50 or 72 ohms (other impedances on special order)
RF Input Level:	0.5 to 20 volts rms
Minimum Input for 100% Current Reference:	2.0 volts rms
Relay Voltage:	-24 volts DC nominal
Power:	105 to 130 volts AC, 50-60 Hz approximately 56 watts (80 watts with PMA-19)
Dimensions, 19 inch rack mounting:	7 inches high x 12 3/4 inches deep behind front panel

.....

Table 1-3 Performance Specifications, PM-19 Precision Monitor (AM-19 with PMA-19)

Frequency Range:	500 KHz to 2000 KHz
Phase Angle Range:	0 to 180 degrees, lead or lag
Phase Accuracy:	± 1.0 degree
Phase Resolution:	0.1 degree
Current Ratio Accuracy:	$\pm 1.0\%$ (20% to 110%)
Current Deviation Range:	$\pm 25\%$
Current Deviation Resolution:	0.1%
Available Patterns:	DA-1 (DA-N), DA-2, DA-3
Maximum Towers:	12 with DA-1 and DA-2 patterns 6 with DA-3 pattern
RF Input Impedance:	50 or 72 ohms (other impedances on special order)

Table 1-3 Performance Specifications, PM-19 Monitor (continued)

RF Input Level	0.5 to 20 volts rms
Minimum Input for 100% Current Reference	2.0 volts rms
Power:	Power is obtained from the AM-19
Dimensions, 19 inch rack mounting	AM-19: 7 inches high x 12 3/4 inches deep PMA-19: 7 inches high x 15 3/4 inches deep behind front panel

.....

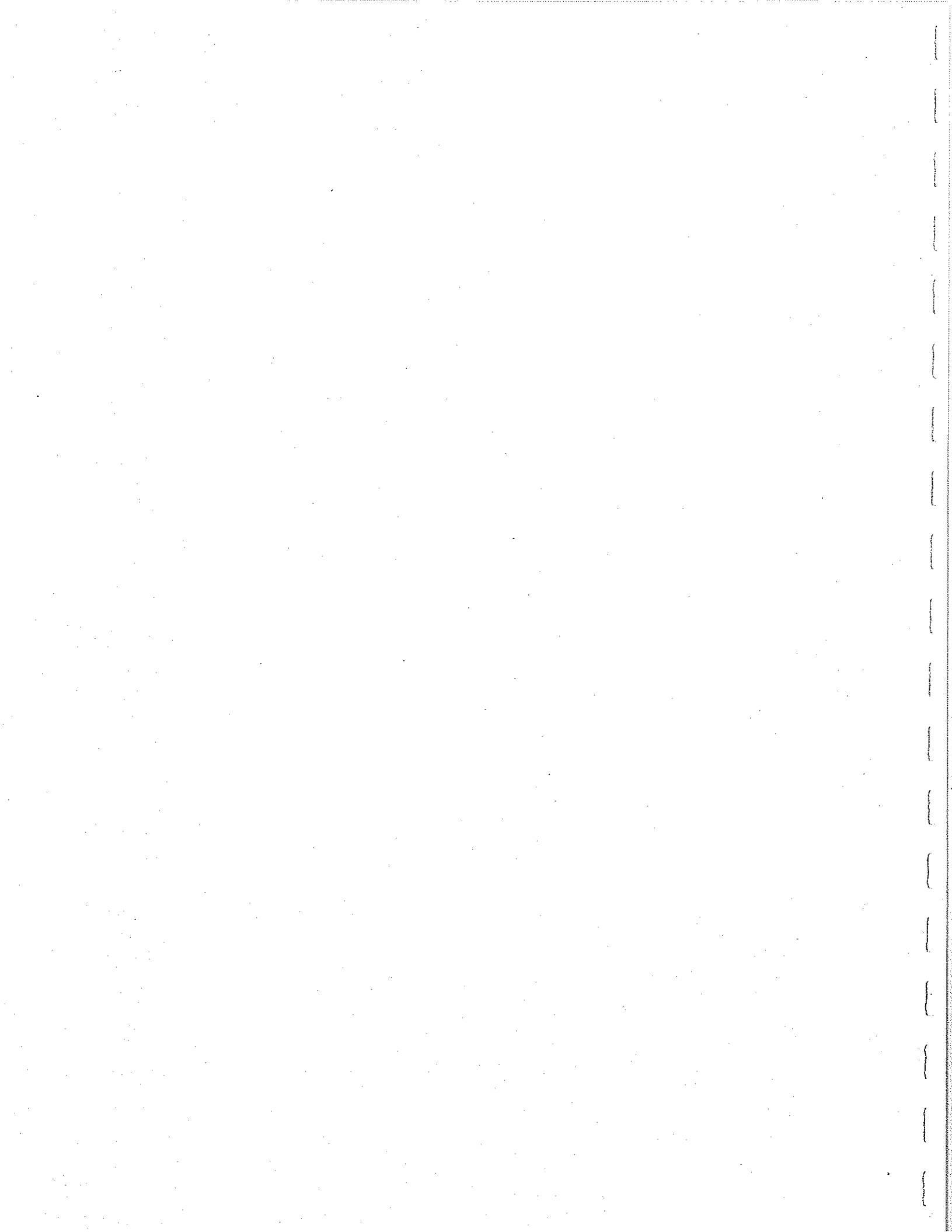

SECTION 2 THEORY OF OPERATION

2.1 AM-19 Antenna Monitor

Figure 11-1 is an overall simplified schematic diagram of the AM-19. The AM-19 Main Chassis schematic diagram is shown in figure 11-2.

2.1.1 Input Module

Figure 11-3 is a schematic diagram of the AM-19 Input Module, however, figure 11-1 may be more useful for understanding its operation.

In the AM-19 space is provided for a maximum of twelve Input Modules. These modules contain the coaxial input receptacle, termination resistance, and tower and pattern selection relays, and are installed according to the requirements of the individual installation, as are the pattern and tower selector push buttons. Special Input Modules are provided for the reference sampling lines. There are no components which are dependent on the operating frequency.

One Input Module is supplied for each tower in the system. Each Input Module contains relay K3. Relays K1 and K2 are included only on those Input Modules used in conjunction with a reference tower.

Relay K3 is the two-pole tower selection relay. One pole connects the tower to the current detector. The second pole connects the tower to the selected tower limiter. This relay is energized by the front panel tower selector push button. Pressing the push button connects Input Module terminal 5 to the +24 volt common, energizing SCR2, which in turn closes K3. When the AM-19 is used with the PMA-19 Precision Monitor Adapter, SCR-2 also energizes the associated tower relay in the PMA-19.

Terminal 13 on the Input Module is connected to terminal 13 on all other Input Modules. This is the selected tower release buss. Energizing any relay produces a negative pulse on the release buss which extinguishes SCR2 in the other modules and disconnects all other towers. In addition to this feature, the +24 volt common is connected in series through the selector switches, which insures that no two towers can be selected simultaneously.

Pressing the DAY front panel push button energizes relays K1 and K2 on the reference Input Module associated with the Day reference tower. The contacts of relay K2 apply the signal from this tower to the reference limiter. The contacts of K1 connect the DAY potentiometer to the Current Meter Module. The current detector consists of C1, CR3 and R11. It is located on the last non-reference Input Module.

In those installations where the reference tower is the same for both day and night operation, the unit will still contain two reference Input Modules. This is necessary to switch the DAY and NIGHT REFERENCE LEVEL potentiometers to accommodate the different current levels in day and night operation. In this case, a jumper is connected from terminal 2 of the Day

reference module to terminal 2 of the Night reference module. Also, the connection is removed from terminal 7 of the Night reference module. These changes allow alternate selection of the DAY and NIGHT potentiometer by the DAY and NIGHT MODE push buttons, and at the same time keep relay K2 in the DAY reference module in the energized condition in both the DAY and NIGHT modes.

2.1.2 Limiter Module

The limiter Module schematic diagram is shown in figure 11-4.

The AM-19 contains two identical Limiter Modules, one for the reference tower channel and one for the selected tower channel. Each module accepts the sinusoidal RF input and "hard limits" the signal to an approximate square wave with well defined zero-axis crossings. This high degree of limiting is maintained in the presence of deep modulation with input levels down to 0.5 volts rms.

Limiting is accomplished by two integrated circuit differential clippers. Within the Limiter all coupling is DC and both phases of the differential outputs are used. Emitter followers are used for coupling between the differential amplifiers and between the Limiter output and the Phase Detector Module.

Zener diode CR4 effectively reduces the DC level at the collector of A1 and allows DC coupling through the emitter followers and into the next limiting stage.

The technique of differentially driving the second limiting stage provides well defined zero axis crossings with sharp rise time. The peaking action of coils L1 and L2 further improve the rise time.

Potentiometer R10 and the calibration panel SYMMetry potentiometer are related adjustments which are used to balance the first differential amplifier. R10 is factory set and is not normally readjusted. However, if required (because of card replacement or repair) readjustment of R10 is a simple matter, and is performed with no input to the unit. The related SYMMetry potentiometer is initially set to its mid-range and R10 is set for a 0.volt difference between TP1 and TP2. Final symmetry adjustments are covered in Section 4, par. 4.1.2.

2.1.3 Sense Circuit

The sense circuit provides a means of determining whether the selected tower phase is leading or lagging the reference tower phase. The sense circuit which is included in the Limiter Module consists of R32, C9, L4, CR3, R31, and C8.

Basically, the sense circuit functions by inserting a small additional phase shift in the input to the reference tower limiter. The circuit is actuated by pressing the SENSE push button switch on the calibration sub-panel which applies a forward bias to diode CR3. The conduction of CR3 effectively shunts the limiter input with the impedance of C8 and R31, and causes a phase delay in the reference signal. Having the resistor in series with C8 maintains a uniform phase shift of approximately 4 degrees over the specified frequency range. The other components in the circuit determine the proper diode current and provide RF isolation. Releasing the SENSE push button returns a high reverse bias to the low capacity diode CR3, and isolates the phase shifting components from the

limiter input. The sense circuit in the selected tower Limiter is not used and the Main Chassis is wired to provide a permanent reverse bias to the switching diode.

The sense indication is more easily interpreted with the aid of figure 2-1 which is a representation of the phase detector response. The phase detector generates a DC voltage which is linearly proportional to the phase angle, with the function increasing from 0 to 180 degrees, and decreasing back to a reading of 0 from 180 to 360 degrees. For angles greater than 180 degrees the PHASE ANGLE meter reading equals 360 degrees minus the angle. For example, 270 degrees will produce a meter reading of $360 - 270 = 90$ degrees, and the same meter reading is obtained for a leading or lagging angle of 10 and 350 degrees, 100 and 260 degrees, 176 and 184 degrees, etc.

If the selected tower phase leads (positive angle) the reference tower phase by some angle from 0 to approximately 176 degrees, pressing the SENSE push button will effect an additional reference phase delay of about 4 degrees causing the meter reading to increase by that amount. If the selected tower phase leads the reference tower phase by some angle from 180 degrees to approximately 356 degrees, the meter indication will equal $360 - \text{angle} - 4^\circ$, and pressing the SENSE push button will cause the meter to decrease.

When a leading phase angle is approximately 4 degrees less than 180 degrees or 360 degrees, the sense indication must be interpreted carefully since the meter reading may "go through" 180 degrees or 360 degrees (0 degrees on the meter). For example, if a selected tower phase leads the reference tower phase by 179 degrees, pressing the SENSE push button will increase the phase to approximately 183 degrees which produces a meter reading of $360 - 183 = 177$ degrees - thus the meter reading will decrease which might be erroneously interpreted as a lagging phase angle.

If the selected tower phase lags (negative angle) the reference tower phase, the PHASE ANGLE meter will read the same as for a leading angle but the sense indication will be reversed. Thus pressing the SENSE push button will cause the phase reading to decrease for lagging angles from approximately 4 degrees to 180 degrees, and increase for lagging angles from approximately 184 degrees to 360 degrees. Again, the sense indication for angles within approximately 4 degrees of 0 or 180 degrees must be interpreted carefully.

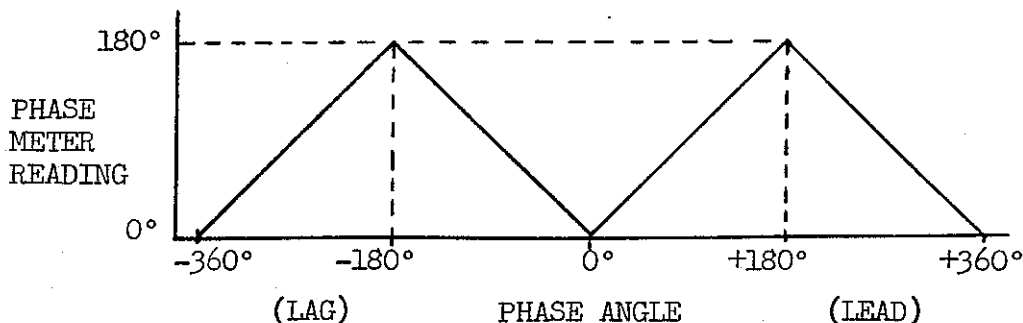

Figure 2-1. Phase Detector Response

The sense ambiguities for phase angles near 0 or 180 degrees can be eliminated by inserting an additional length of coaxial cable in the sampling lines from the towers in question.

2.1.4 Phase Detector Module

The Phase Detector schematic diagram is shown in figure 11-5.

The Phase Detector Module develops a DC voltage proportional to the phase difference between the reference and selected tower signals. The phase comparison is made by a dual differential "coincidence" amplifier. This dual configuration cancels the effects of any asymmetry which might be present in the inputs and provides a very precise phase indication.

Transistors Q7 through Q10 function as constant current sources. These current sources establish the precise DC reference levels which are necessary for accurate phase detection.

Inputs A and B are from the reference channel limiter and are always 180 degrees out of phase. Inputs C and D are from the selected channel and are also 180 degrees out of phase.

Transistor Q1, 2, 3 and 8 form one phase detector circuit. The limited reference tower input is applied at the base of Q1; the limited selected tower input at the base of Q3. When either input signal is positive, the associated transistor is turned on. This places a positive potential at the emitter of Q2. Since the Q2 base is at ground potential, it is cut off under this condition. When both inputs go negative, Q2 turns on. Thus the level at the collector of Q2 alternately switches in the positive and negative directions. The width of the negative going pulse is determined by the time during which both inputs are negative. This, in turn, is determined by the phase angle between them. For a zero phase angle, the signal at the Q2 collector is a symmetrical square wave, and the voltage at C5 has its maximum negative value. The difference between the voltage drops across resistors R30 and R32 is then zero.

When the phase angle changes from 0 degrees, the positive going pulse at the collector of Q2 becomes wider and the voltage at C5 becomes more positive. At a phase angle of 180 degrees there is no current in Q2 or R30, and this voltage reaches its maximum positive value.

The voltage at C5 is applied through the 180 degrees push button switch to the integrated circuit operational amplifier. This is a high stability low gain device which drives the front panel PHASE ANGLE meter. Two other outputs are also provided: one for the PMA-19, Precision Monitor Adapter and one for an external application such as an automatic logging device. These outputs may or may not be used, depending on the system.

The other half of the phase detector, Q4, 5, 6 and 9 is performing the same phase comparison but on the inverse phases. Since the actual net charge on C5 is the result of both comparisons, any non-symmetry in the input is "averaged out" by this circuit configuration.

Two adjustments are associated with the Phase Detector Module: the 0 degrees adjustment and the 180 degrees adjustment. By selecting the in

use reference tower, there will be a 0 degrees difference between the two inputs to the Phase Detector. Under this condition, the ZERO PHASE adjustment is set for a 0 degrees reading on the PHASE ANGLE meter. (The ZERO PHASE potentiometer is located on the calibration sub-panel behind the hinged front panel name plate.)

With a 180 degrees phase difference, Q2 and Q5 are always cut off and the charge on C5 reaches the value established by zener diode CR2. This condition is simulated by pressing the 180 degrees adjust switch which connects CR2 directly to the operational amplifier. With the switch pressed, the 180 degrees potentiometer is set for a 180 degrees reading on the PHASE ANGLE meter. This potentiometer "fine adjusts" the level at CR2 by controlling the constant current supplied by Q10. Simultaneously, the constant current supplied by Q8 and Q9 is also adjusted. This maintains the same current ratio through R30 and R32 and minimizes interaction between the 0 degrees and 180 degrees adjustments.

However, there is a slight amount of interaction between the two adjustments. The 0 degrees adjustment should be set first, then the 180 degrees adjustment. This procedure should be repeated until both the adjustments are correct.

2.1.5 Current Meter Module

The Current Meter Module schematic diagram is shown in figure 11-6.

The Current Meter Module includes an integrated circuit operational amplifier. This circuit provides isolation and gain between the loop current detector and the indicating devices including the LOOP CURRENT meter, the PMA-19, and any external devices. This degree of isolation and gain results in excellent stability and linearity over a wide dynamic range.

The gain of the operational amplifier is a function of the ratio between the feedback resistor R11 and the composite input resistance which includes R8 and the DAY, CRITICAL HOURS or NIGHT potentiometer selected by the MODE relays. Adjusting the LOOP REFERENCE potentiometer changes the gain of the amplifier. Initially the LOOP REFERENCE control for each mode is set to provide a convenient reference level, usually 100%, with the reference tower selected. If the reference tower is not the highest current level in the array, the potentiometer should be adjusted for some lower level which will allow convenient reading.

Potentiometer R7 is a factory adjustment used to compensate for the forward drop which occurs across the current detector diode. It is set to provide a slight up-scale reading on the meter with no current input.

Diodes CR1 and CR2 are limiters which prevent current surges from overloading the circuit.

Integrated circuit A2 is a diode rectifier which is part of the 24 volt DC supply for operation of the relays and push button lamps.

2.1.6 Power Regulator Module

The Power Regulator Module schematic diagram is shown in figure 11-7.

The Power Regulator Module develops the regulated plus and minus 12.5 VDC used throughout the AM-19. When the unit is used as part of a PM-19 system, this supply also furnishes operating voltage to the PMA-19.

The regulators for the +12.5 and -12.5 volt supplies are identical. The 21 volt AC supply is rectified by bridge rectifier CR1 and filtered by a chassis mounted 500 uf capacitor producing about 26 volts. Load current flows through Q3 and the chassis mounted 2N3054 (Q1). These two transistors are connected in a Darlington configuration. Changes in output voltage, caused by either a change in line voltage or load, are sensed by Q5 through divider R8, R7, and R11. Zener diode CR9 maintains the emitter of Q5 at a constant -6.2 volts. The output variations are amplified by Q5 and applied to the base of Q3, changing the series resistance in the direction that opposes the original output voltage change. R11 is adjusted to set the output voltage at exactly 12.5 volts.

Transistor Q1 is a high impedance collector load for Q5. In conjunction with R3, R5, and CR3, it provides short circuit protection for the regulator. If the load current increases to about 300 MA, the voltage drop across R5 causes CR7 to conduct. Q4 then becomes nearly cut off, limiting the current into the collector of Q3 and increasing the resistance of the series transistor. An equilibrium point is reached when the load current is limited to 300 MA even if the load resistance is reduced to a short circuit.

Temperature compensation is provided in several places. CR4 compensates for the temperature change of the base-emitter diode of Q4. CR8 is a temperature compensated zener diode having a temperature coefficient of .005%/degree C. CR11 and CR12 compensate for the temperature range of the base-emitter diode of Q3.

SECTION 3 INSTALLATION AM-19

3.1 Inspection

After carefully unpacking the instrument, check that the following items have been included with the AM-19:

- a. One per unit - Instruction Manual
- b. One per unit - Power cord, 3 conductor with 3-prong U-grounding plug.
- c. One per unit (supplied with remote metering panel) - Remote control connector, 33 contact plug, Cinch-Jones P-333-CCT.

Inspect the packing cartons, particularly the inner box, for any indication of damage to the equipment in shipment. Thoroughly inspect the Antenna Monitor. Check all sides of the unit for signs of damage, check the meters, operate all controls checking for looseness or binding. If there are any signs of rough handling, remove the top and bottom covers, look for broken wires and check that all plug-in modules are properly seated.

NOTE: The AM-19 includes two identical limiter modules. However, these modules cannot be interchanged without upsetting certain factory adjustments. If it is necessary to remove any modules, be sure each board is plugged back into the original socket.

On some models the reed relays located on the input modules are plugged into pin sockets. Also check that these relays are properly seated.

The shipping container has been specifically designed to protect this equipment from damage during normal transport. Any physical damage to the monitor is an indication of gross mishandling and the carrier should be notified immediately.

It is strongly suggested that the inner and outer shipping cartons and all filler and pads be retained at least until the monitor has been checked out and is operating properly in the system. In the event the unit must be returned to the factory, SHIPMENT IN AN IMPROPER CONTAINER MAY VOID THE WARRANTY.

3.2 Monitor Configuration

Before mounting the AM-19, determine that the monitor configuration complies with all requirements of the installation. The number of TOWER push buttons and rear panel coaxial receptacles should correspond to the number of towers in the array. For a single pattern (DA-1, DA-D or DA-N) array the monitor will include a push button POWER switch, a RMT (remote) push button, a RLS (release) push button and one LOOP REFERENCE ten-turn counting dial. Calibration adjustments are located on the calibration sub-panel behind the hinged door on the lower left area of the front panel. For a two pattern (DA-2) array the monitor will include two additional MODE push buttons for DAY and NIGHT, and LOOP REFERENCE dials for both DAY and NIGHT. For a three pattern (DA-3) array the monitor will include

MODE push buttons for DAY, CRITICAL HOURS, and NIGHT, and three LOOP REFERENCE dials for DAY, CRITICAL HOURS and NIGHT. The sampling line input impedance is specified on order as 50 ohms or 72 ohms; if in doubt, the resistance can be measured with an ohmmeter.

3.3 Mounting and Power

All units of the Type 19 System are designed for mounting in a standard 19 inch wide rack. The precision meters and dials are most conveniently read with the AM-19 installed approximately at eye level. The sampling lines, power, and remote control connection are made at the rear of the unit.

The monitor will provide full performance in an ambient (surrounding air) temperature range from 0°C (+32°F) to 50°C (122°F). The power dissipation of the solid state AM-19 is quite low, but if the unit is mounted in the vicinity of high wattage vacuum tube equipment, sufficient ventilation must be provided around all surfaces of the chassis so as not to exceed the ambient temperature limit. Direct radiation from high temperature devices should also be avoided. For a maximum stability of readings, the monitor should not be installed in an area where the ambient temperature varies over a wide range, such as near an air conditioner outlet or above intermittently used equipment.

The AM-19 is designed to operate from a power source of 105 to 130 volts AC, 50 to 60 Hz, single phase. The power cord connector should be firmly inserted in the rear panel power inlet. (Rotate "twist lock" sockets clockwise to lock connector in place.) TO PREVENT A POSSIBLE SAFETY HAZARD AND TO REDUCE HUM, NOISE AND RF PICKUP TO A MINIMUM, THE POWER CORD SHOULD BE PLUGGED INTO A PROPERLY POLARIZED (NEMA) 3 CONDUCTOR U-GROUNDED AC RECEPTACLE.

The AM-19 power supply is protected with the rear panel fuse. The AC outputs on the remote control connector (J1) and the PMA-19 connector (J2) are turned off with the push button POWER switch but are not fused. Because the POWER switch controls the AC power to other units of the Type 19 System, the red POWER light remains energized when the AM-19 fuse is blown.

Do not turn on AC power until instructed in Section 4.

3.4 Antenna Connections

CAUTION: A continuous sampling line voltage in excess of 20 volts RMS (unmodulated) can cause permanent damage to the AM-19 input terminating resistors, even when AC power is removed. This input voltage limit must be observed for all patterns and also non-directional operation if the powered tower remains connected to the monitor. See par. 3.4.2. If in doubt, the voltage should be measured with the sampling lines properly terminated in a high wattage load. An overload is also indicated by a LOOP REFERENCE dial setting of less than 1.00 turns cw for a 100% LOOP CURRENT reading.

3.4.1 Sampling Lines

When installing the sampling lines it is recommended that the cable

lengths be as nearly equal as possible, both to preserve the absolute accuracy of the phase measurements, and also to "cancel" variations in line characteristics due to temperature changes and other causes.

An important exception to this rule is sometimes made for those arrays which produce measured phase angles near 0 degrees. In this case the sense (leading or lagging) indication of a phase angle must be interpreted carefully, and also the monitor is most susceptible to interference at these angles. If desired, these effects may be eliminated by inserting an extra length of coaxial cable in series with the sampling lines from the towers in question. The length of the extra cables should be sufficient to effect a phase delay of about 5 degrees as determined from the following formula:

$$\text{LENGTH OF CABLE (FEET)} = \frac{2733 \cdot V \cdot \text{PHASE DELAY (DEGREES)}}{\text{OPERATING FREQUENCY (KILOCYCLES)}}$$

V (Cable Velocity Factor) = 0.85 for air-spaced dielectric
= 0.67 for solid polyethylene dielectric
(ei. RG-8/U, RG-58/U, RG-59/U)
= 0.695 for solid teflon dielectric

EXAMPLE: Use 9.15 feet of RG-8/U for 5 degrees delay at 1000 KHz

The "extra" cable should be installed in a protected location where temperature extremes are minimized.

3.4.2 Non-Directional Voltage Limit

In a DA-D or DA-N system, it is important to determine the sampling line voltage from both the powered and unpowered towers during non-directional operation. To avoid damage in cases where the specified voltage limit is exceeded, a coaxial relay can be utilized to transfer the sampling lines from each overloaded input receptacle to a dissipating resistance during non-directional operation. The relay coils can be energized by a phasor contactor utilizing either the 24 volt supply in the monitor (pins 23 and 24 of J1) or an external power source.

3.4.3 Input Module Connections

The coaxial cables from the antenna sampling loops are connected to UHF receptacles on the rear of the AM-19. Each coaxial receptacle is mounted on an input module which contains the switching relays and critical RF circuits repeated for each tower. The input modules are assembled across the rear of the monitor with one module provided for each antenna tower up to a maximum of 12.

Two types of input modules are utilized in the AM-19. These are designated either as reference tower input modules or as non-reference tower input modules.

In a monitor equipped for a single pattern system, that is for a DA-1,

DA-D or DA-N configuration, the reference input module is installed in the left-most position as seen viewing the rear of the chassis. For a two pattern or DA-2 configuration, the DAY reference input module is installed in the left-most position, and the NIGHT reference input module is mounted adjacent to the right of the DAY module. For a three pattern or DA-3 configuration, the DAY, NIGHT and CRITICAL HOURS reference input modules are installed in that order starting from the left-most module position. Thus the reference input modules always occupy the first, second and third left-most position as required for the installation, and the non-reference input modules follow from left to right for a total number of input modules equal to the number of towers in the array.

This arrangement, which is desirable to insure minimum lead length of the critical phase measurement circuits, sometimes results in the rear panel tower connections being out of numerical sequence. However, the reference and non-reference tower inputs are clearly numbered for each installation, and the front panel TOWER push buttons are factory wired in proper numerical order.

On occasion the same reference tower may be specified for two or even all three patterns. However, since it may be necessary to change the designated reference towers after the initial installation of the monitor, the AM-19 is always provided with a separate reference input module for each pattern. A reference module which is not utilized as a reference tower input for a particular pattern will always serve as a non-reference input.

If no changes have been made in the reference tower designation originally specified for the monitor, simply connect the sampling lines from each tower to the correspondingly numbered coaxial input connectors on the rear of the AM-19.

If it is necessary to change the reference tower for any pattern, refer to par. 3.5 below.

3.5 Changing Reference Towers

3.5.1 DA-1 Monitor

In a single pattern system the sampling line from the reference tower must be connected to the reference input module which is always installed in the left-most module position as viewed from the rear of the chassis. To change reference towers it is necessary to interchange the "new" and "old" reference tower sampling line connections at the rear of the monitor so the new reference tower sampling line is connected to the left-most input module.

This procedure will result in an incorrect numbering of the sampling line connections and the front panel TOWER push buttons. To restore the proper tower number sequence continue to par. 3.5.3 below.

No reference module wiring changes are necessary when changing reference towers in a DA-1 installation.

3.5.2 Reference Module Connections - DA-2 and DA-3 Monitors Only

To change the reference towers in a DA-2 or DA-3 system it is necessary to change an easily accessible jumper wire located on the printed circuit board

of the reference input module; this is accomplished as follows:

1. Remove the top cover of the AM-19.
2. In a DA-2 or DA-3 installation, the sampling line from the DAY reference tower must always be connected to the DAY reference module which occupies the left-most module position as viewed from the rear of the chassis. A jumper (No. 22 buss wire with sleeving) is always soldered from terminal 2 (counting from the top of the p-c board) of the DAY reference module to terminal 7 of the same module.
3. If the NIGHT reference tower is different from the DAY reference tower, connect the sampling line from the NIGHT reference tower to the NIGHT reference module. Solder a jumper from terminal 2 of the NIGHT reference module to terminal 7 of the same module.
4. If the DAY and NIGHT reference towers are the same, delete the connections called for in step 3 and solder a jumper from terminal 2 of the DAY reference module to terminal 2 of the NIGHT module.
5. If the CRITICAL HOURS reference tower is different from the DAY and the NIGHT reference towers, connect the sampling line from the CRITICAL HOURS reference tower to the CRITICAL HOURS reference module. Solder a jumper from terminal 2 of the CRITICAL HOURS reference module to terminal 7 of the same module.
6. If the CRITICAL HOURS and NIGHT reference towers are the same, delete the connections called for in step 5 and solder a jumper from terminal 2 of the CRITICAL HOURS reference module to terminal 2 of the NIGHT reference module.
7. If the CRITICAL HOURS and DAY reference towers are the same, delete the connections called for in steps 5 and 6 and solder a jumper from terminal 2 of the CRITICAL HOURS reference module to terminal 2 of the DAY reference module.
8. If the DAY, NIGHT and CRITICAL HOURS reference towers are all the same, delete the connections called for in step 5 and solder a jumper across terminal 2 of all three reference modules.
9. The sampling lines from the non-reference towers should be connected to the monitor in the order which minimizes the changes in the TOWER numbering sequence.

3.5.3 Changing TOWER Numbers

As a result of changing reference towers, the tower connections to the AM-19 may no longer correspond to the numbers on the rear panel and on the TOWER push buttons. These numbers should be rearranged as necessary. The simplest approach to rearranging the TOWER push buttons is to pull off the numbered lense caps (as if changing lamps) and replace in the proper order corresponding to the new tower connections.

If it is desired to preserve the 1, 2, 3 numerical sequence of the TOWER push buttons, this can be easily accomplished as follows:

1. Note the wires connected to terminal 5 and 6 of the input modules. Both wires will have the same base color but the wire to terminal 6 will have a white tracer. The color of the wires to each module will follow the RETMA color code for the module order counted from the left side of the chassis looking at the rear. (But remember that the module order is usually different from the TOWER numbers.) For example, the wires to terminals 5 and 6 of the third module from the left will be orange and orange & white respectively. These wires are brought to terminal 4 and B on the back of the TOWER push button switches with the tracer wire always connected to B.
2. Resolder the connections at the back of the TOWER push buttons so the pair of colored wires coming from the input module for each numbered tower is connected to the correspondingly numbered push button switch. For example, if tower 5 is connected to the third input module from the left, the orange and orange & white wires should be connected to terminals 4 and B respectively of TOWER push button 5.
3. Replace the top cover of the AM-19.

3.6 Remote Control and Metering Connections

The Type 19 System is designed to function in a variety of remote control and automatic logging configurations.

All remote control and metering connections to the AM-19 are made through connector J1 (33 pins), on the rear of the monitor. A separate connector, J2 (27 pins), is provided for interfacing with certain Type 19 auxiliary equipment such as the PMA-19.

All AM-19 interface connections are listed in table 3-1. Also see Figure 11-14 which diagrams a typical remote control installation.

3.6.1 Relay Operation

Remote operation of the AM-19 is accomplished by externally energizing the monitor relays which are locally actuated by the front panel TOWER and DAY, NIGHT push buttons. The monitor relays can be energized from a transmitter control unit or a remote switching adapter connected in either of the following configurations:

- a. Remote Override - Contact Closures to Ground: In this configuration jumper wires must be soldered in the J1 mating plug from pin 23 to pin 26, and from pin 24 (24V -) to pin 14 (ground). Contact closures from pins 1-12, 13, 15, 16 to pin 24 will energize the monitor relays with the RMT (Remote) push button either ON (lighted) or OFF. Remote contact closures will automatically release locally selected push buttons, but not vice-versa; to prevent local tower or pattern selection during remote control, the RMT push button should be ON.

- b. Independent Local/Remote - Floating Contact Closures: In this configuration a jumper wire must be soldered in the J1 mating plug from pin 23 to pin 26. Contact closures from pins 1-12, 13, 15, 16 to pin 27, will energize the monitor relays only when the RMT push button is ON (lighted). The remote contact closures must be isolated from ground. As an option, pin 24 (24V -) can be grounded with a jumper to pin 14, without effecting this mode of switching. Local tower and pattern selection is obtained with RMT push button OFF. Also see par. 3.6.4.

CAUTION: Unfused 117V AC is accessible at pins 22 and 25 of J1. Also the +12.5 volts (pin 19), -12.5 volts (pin 20) and the 24 volts common (pin 23) connections must never be grounded since this will place a direct short circuit across the AM-19 power supply.

3.6.2 Phase Meter Calibration

A "two point" calibration of the AM-19 PHASE meter can be obtained through the remote control system. The zero degrees calibration is automatically checked when the reference tower relay is energized during the phase reading sequence. The 180° calibration is checked by a contact closure between pins 18 and 19 (+12.5V) of J1 which duplicates the function of the 180° push button on the cal-panel. The 180° cal contacts must be isolated from ground and from all relay energizing circuits in the remote control system.

3.6.3 Remote Sense Indication

As an option, the AM-19 can be factory wired with a J1 connection for remotely energizing the phase sense circuit. See par. 2.1.3 and 4.2.2. To duplicate the function of the SENSE push button, a remote contact closure is made from pin 21 to pin 19 (+12.5V) of J1. The remote sense contacts must be isolated from ground and from all relay energizing circuits. To obtain a meaningful sense indication, provisions must be made to simultaneously energize the appropriate tower relay and the sense function, while metering the phase analog voltage.

Contact Potomac Instruments for details on this option.

3.6.4 Local Alarm

Normal maintenance of a remote control system will occasionally require operating the antenna monitor "locally" at the transmitter site. If an operator inadvertently fails to energize the RMT push button before leaving the premises, it may not be possible to operate the monitor remotely. See par. 3.6.1, b. The AM-19 is provided with an isolated pair of switch contacts (pins 28 and 31 of J1) which are closed when the RMT push button is in the local (de-energized) position. These contacts can be used (often in conjunction with like functioning contacts in other remote control equipment) to operate a "local" alarm or light which shows when the system is not switched for remote control.

3.6.5 Analog Outputs

Voltage analogs of the LOOP CURRENT and PHASE meter readings are simultaneously available at the auxiliary outputs of J1.

The outputs at pins 29 and 32 are normally utilized in conjunction with the remote control system to operate remote indicating devices such as the RMP-19 Remote Metering Panel. The voltage at these outputs is adjusted with the rear panel LOOP CURRENT and PHASE potentiometers respectively, and varies from zero to an adjustable maximum of at least 5.0 volts (open circuit) corresponding to a deflection of the AM-19 meters from 0 to full scale. The auxiliary output (source) resistance varies with control setting to a maximum of approximately 2800 ohms; the minimum recommended load impedance is 5000 ohms.

When not connected in a remote control system, the analog outputs at pin 29 and 32 of J1 can be utilized to operate locally installed equipment such as an RMP-19 or various types of chart recorders. Additional auxiliary outputs can be easily added. The AM-19 is provided with spare J1 pins and extra rear panel mounting holes for an additional LOOP CURRENT control and PHASE control. These optional potentiometers are normally 10,000 ohms, either of the miniature multiturn type (such as Bourns 3052S-1-103M) or the precision 10 turn type (such as Bourns 3500S-2-103), and are connected to R6, R7 and J1 as shown on the AM-19 schematic figure 11-2. The optional bridging resistors are recommended when providing an output to a digital voltmeter; the resistor values are usually calculated for a vernier adjustment to 1.000 volts and 1.800 volts corresponding to meter readings of 100% and 180° respectively.

Table 3-1 AM-19 Interface Connections

<u>J-1 - Remote Control</u>	<u>J2 - Precision Monitor Adapter</u>
1-12 Tower Relays 1 thru 12 (1) (2)	1-17 Same as J1
13 Day Relay (1)	18 Current Ratio Voltage
14 Ground	19 +12.5V DC Regulated
15 Night Relay (1)	20 -12.5V DC Regulated
16 Critical Hours Relay (1)	21 Phase Voltage
17 Ground	22 117V AC High Switched
18 180° Cal (Contact Closure to Pin 19)	23 24V DC (+) with RMT, RLS OFF
19 +12.5V DC Regulated	24 24V DC (-) with RMT OFF
20 -12.5V DC Regulated	25 117V AC Neutral
21 *Sense (Contact Closure to Pin 19)	26 No Connection
22 *117V AC High Switched	27 180° Calibration
23 24V DC (+)	
24 24V DC (-)	
25 *117V AC Neutral	
26 Remote (+) (Jumper to Pin 23)	
27 24V DC (-) with RMT ON, open with RMT OFF	
28 Isolated Contact Closure to Pin 31 with RMT OFF	
29 Current Ratio Metering Output - Adjustable	
30 *Auxiliary Current Ratio	
31 Local Alarm (See Pin 28)	
32 Phase Metering Output - Adjustable	
33 *Auxiliary Phase	

*Option connection not included in all units.

(1) Relays are energized with contact closure to 24V (-), Pin 24 or Pin 27.

See par. 3.6.1.

(2) Pins 1,2,3 12 correspond to left-to-right sequence of sampling line inputs; not necessarily the same as TOWER number.

3.6.6 Audio Output

The loop current detector in the AM-19 is basically an ultra-linear carrier rectifier, and as such the circuit provides a faithful reproduction of the carrier modulation. Advantage is taken of this feature to provide a low distortion audio output from the monitor which can be utilized for a variety of testing and monitoring functions.

An unbalanced audio output is provided at a standard phone jack on the AM-19 cal-panel. The audio level is normalized with the LOOP REFERENCE control, and the highest output and lowest distortion are usually obtained with the reference tower selected. An output voltage of approximately 1 volt rms is obtained with a LOOP CURRENT meter indication of 100%. The output (source) impedance is nominally 600 ohms. With a 600 ohm load resistance, the frequency response extends from 50 Hz to 15 KHz \pm 1 db, with typical harmonic distortion of less than 1%.

3.6.7 Automatic Logging

Two general methods of automatic logging are possible with the Type 19 System. A common arrangement makes use of various types of analog chart recorders which provide a continuous graphical record of the logged parameters. As indicated above, chart recorders can be connected directly to the phase and loop current outputs of the AM-19.

Alternatively, because of the inherently simpler, more accurate, and stable operation of digital type printers, these devices are finding ever increasing use in broadcast logging applications. The PMA-19 can be provided with BCD (binary coded decimal) outputs for driving digital printers which provide a direct numerical print-out of each recorded parameter.

Regardless of the method of data logging, a completely automatic system must include circuitry for the sequential selection of the antenna monitor tower and pattern relays and the logged station parameters including the phase and loop current readings. Timing and out-of-limit indications are also usually required. For more detailed information concerning digital and automatic logging contact Potomac Instruments, Inc.

The installation of the RMP-19, RMP-19D and PMA-19 are covered in the supplementary sections of this manual. These sections contain additional detailed information on interfacing with remote control systems.

SECTION 4 CALIBRATION AND OPERATION, AM-19

4.1 Calibration

4.1.1 Initial Turn-on

1. The sampling lines should be properly connected to the AM-19 Tower inputs as instructed in Section 3 of this manual. Recheck that the non-reference tower and the reference tower connections for each pattern correspond to the numbered UHF receptacles.

CAUTION: A continuous sampling line voltage in excess of 20 volts RMS (unmodulated) can result in permanent damage to the AM-19 input terminating resistors. An overload condition is indicated by a LOOP REFERENCE dial setting less than 0.9 for a 100% LOOP CURRENT meter reading (see par. 4.1.4).

2. Only if necessary and before applying power, carefully adjust the mechanical "Zero" on both meters.
3. Turn power on by pressing the POWER push button.

NOTE: Allow at least 30 minutes warm-up before calibrating the monitor. Calibration adjustments must be performed with the normal sampling loop signals (voltage and phase) applied to the monitor.

4.1.2 Phase Null Adjustment

NOTE: The PHASE NULL capacitor is utilized to balance out stray capacitance at the station frequency and normally need only be adjusted once. However, readjustment will be required if the station frequency is changed, if modules or relays are replaced or if repairs are made to the phase measurement circuits of the monitor. The capacitor should be adjusted slowly to allow for the response of the highly damped PHASE ANGLE meter. If the optimum adjustment of the screwdriver slot is horizontal, the capacitor is out of range indicating some difficulty in the monitor or in the adjustment sequence.

1. Open the small door to the calibration sub-panel (on lower left area of front panel).
2. Press the MODE push button for the antenna pattern in use* (DAY CRITICAL HOURS, NIGHT).

3. Press the TOWER push button corresponding to the reference tower for the pattern in use.
4. Slowly adjust the PHASE NULL capacitor on the cal-panel for an optimum null (meter deflection toward the left) on the PHASE ANGLE meter.
5. Proceed with the Phase Calibration par. 4.1.3.

4.1.3 Phase Calibration

1. Open the small door to the calibration sub-panel.
2. Press the MODE push button for the antenna pattern in use* (DAY, CRITICAL HOURS, NIGHT).
3. Press the TOWER push button corresponding to the reference tower for the pattern in use. The PHASE ANGLE meter should read very close to 0 degrees.
4. Adjust the ZERO PHASE potentiometer on the cal-panel for 0 degrees on the PHASE ANGLE meter.
5. Press the 180 degrees push button on the cal-panel. The PHASE ANGLE meter should read very close to 180 degrees. Adjust the 180 potentiometer directly above the push button on the cal-panel for 180 degrees reading on the PHASE ANGLE meter.
6. Repeat steps 4 and 5 until the PHASE ANGLE meter reads correctly at both 0 and 180 degrees.

The monitor is now ready to measure the phase difference between the reference tower and any tower selected with the TOWER push buttons.

4.1.4 Current Ratio Calibration

1. Press the MODE push button for the antenna pattern in use*.
2. Press the TOWER push button corresponding to the reference tower for the pattern in use.

* Disregard this step for DA-1 or DA-N monitors since these models do not include pattern push buttons.

3. Adjust the ten-turn LOOP REFERENCE potentiometer corresponding to the pattern in use for the REF (100%) index on the LOOP CURRENT meter. (The minimum sampling loop input level to obtain a 100% reading on the LOOP CURRENT meter is approximately 2.0 volts RMS.)

In some arrays one or more tower currents may be greater than 100% of the reference current. The AM-19 will indicate up to 110% of the reference tower current. If a selected tower ratio exceeds 110%, the LOOP REFERENCE controls on the AM-19 can be adjusted for a reference tower setting of less than 100%. 50% is often used for ease in calculating the ratios. (2 x meter indication)

The monitor is now ready to measure the Loop Current Ratio of any selected tower directly in percentage of the reference tower current.

4.2 Operation

4.2.1 Phase Measurement

1. Press the MODE push button for the antenna pattern in use* (DAY, CRITICAL HOURS, NIGHT).
2. As a check on calibration, press the TOWER push button corresponding to the reference tower for the pattern in use. The PHASE ANGLE meter should read 0 degrees.
3. Press the TOWER push buttons in any sequence. The PHASE ANGLE meter will provide a direct indication of the phase difference from 0 to 180 degrees between the reference tower and any selected tower.

4.2.2 Sense

1. To determine whether the measured phase angle is leading or lagging the reference phase, press the SENSE push button on the Cal-panel. If the selected tower phase is leading the reference tower, the indicated phase angle will increase approximately 4 degrees and vice versa.
2. If the phase angle is within approximately 4 degrees of 0 or 180 degrees, the SENSE indication must be used carefully since the phase change may "go through" 0 or 180 degrees giving an erroneous indication of sense. This effect can be eliminated by inserting an extra length of coaxial cable in the sampling lines from the towers in question. (See par. 3.2)

4.2.3 Current Ratio Measurement

1. Press the MODE push button for the antenna pattern in use* (DAY, CRITICAL HOURS, NIGHT).

2. Press the TOWER push button corresponding to the reference tower for the pattern in use. The LOOP CURRENT meter should deflect to the reference setting adjusted in step 3 of paragraph 4.1.4. (The reference setting is usually 100% but a lower setting such as 50% may be utilized for some patterns.)
3. On occasion the LOOP CURRENT meter will not indicate the correct reference setting when the reference tower is selected. This effect may result from normal changes in the transmitter output power or disturbances in the antenna pattern. In this event, either one of two alternate procedures may be followed.

Procedure A

- 4A Press the TOWER push buttons in any sequence and log the LOOP CURRENT meter reading for all towers including the reference tower.
- 5A Calculate the loop current ratios for each tower in percentage of the reference tower current as follows:

$$\text{TOWER RATIO (\%)} = \frac{\text{TOWER READING}}{\text{REFERENCE READING}} \times 100$$

Procedure B

- 4B Readjust the LOOP REFERENCE potentiometer corresponding to the pattern in use for the correct reference setting on the LOOP CURRENT meter.
- 5B Press the TOWER push buttons in any sequence. The LOOP CURRENT meter will provide an indication of the loop current ratio of any selected tower directly in percentage of the reference tower current.
- 6B It is often useful to log the LOOP REFERENCE dial reading after each readjustment of the reference setting. Because of the excellent linearity of the LOOP REFERENCE potentiometer, the dial readings can provide an accurate and repeatable record of the relative reference tower current or power. The following formulae relate the change in sampling line voltage (V), current (I), or power (P) to the dial readings (T).

$$V = \frac{0.2M}{T} \quad ; \quad \frac{V_1}{V_2} = \frac{I_1}{I_2} = \frac{T_2}{T_1} \quad M = \text{LOOP CURRENT METER READING}$$

$$\Delta I (\%) = \left(\frac{T_1}{T_2} - 1 \right) \times 100 \quad ; \quad \Delta P (\%) = \left(\frac{T_1^2}{T_2^2} - 1 \right) \times 100$$

4.3 Lightning and Overload Protection

To avoid damage to the antenna monitor from surges on the sampling lines, a Release (RLS) mode is provided whereby all AM-19 circuitry, except the input terminating networks, is disconnected by relays from the sampling lines. The RLS push button should be pressed in response to an approaching electrical storm, or before transmitter or antenna adjustments not requiring the monitor. It is generally recommended that the monitor be left in the "release" condition between readings.

4.4 Remote Control

To operate the AM-19 by remote control it is normally necessary to depress the RMT (remote) push-ON-push-OFF MODE switch. When ON, the RMT push button is lighted and all TOWER and other MODE push buttons are inoperative, thus preventing "local" operation of the monitor.

However, as the monitor tower and pattern relays are energized by the remote control systems, the corresponding front panel TOWER and DAY, NIGHT or CRIT HRS push buttons will be lighted, providing the local operator with an immediate and unambiguous determination of the monitor condition. The AM-19 meters, auxiliary outputs, and calibration functions operate normally in the remote control mode.

To return the monitor to local control, press and release the remote push button OFF, which will extinguish the RMT lamp.

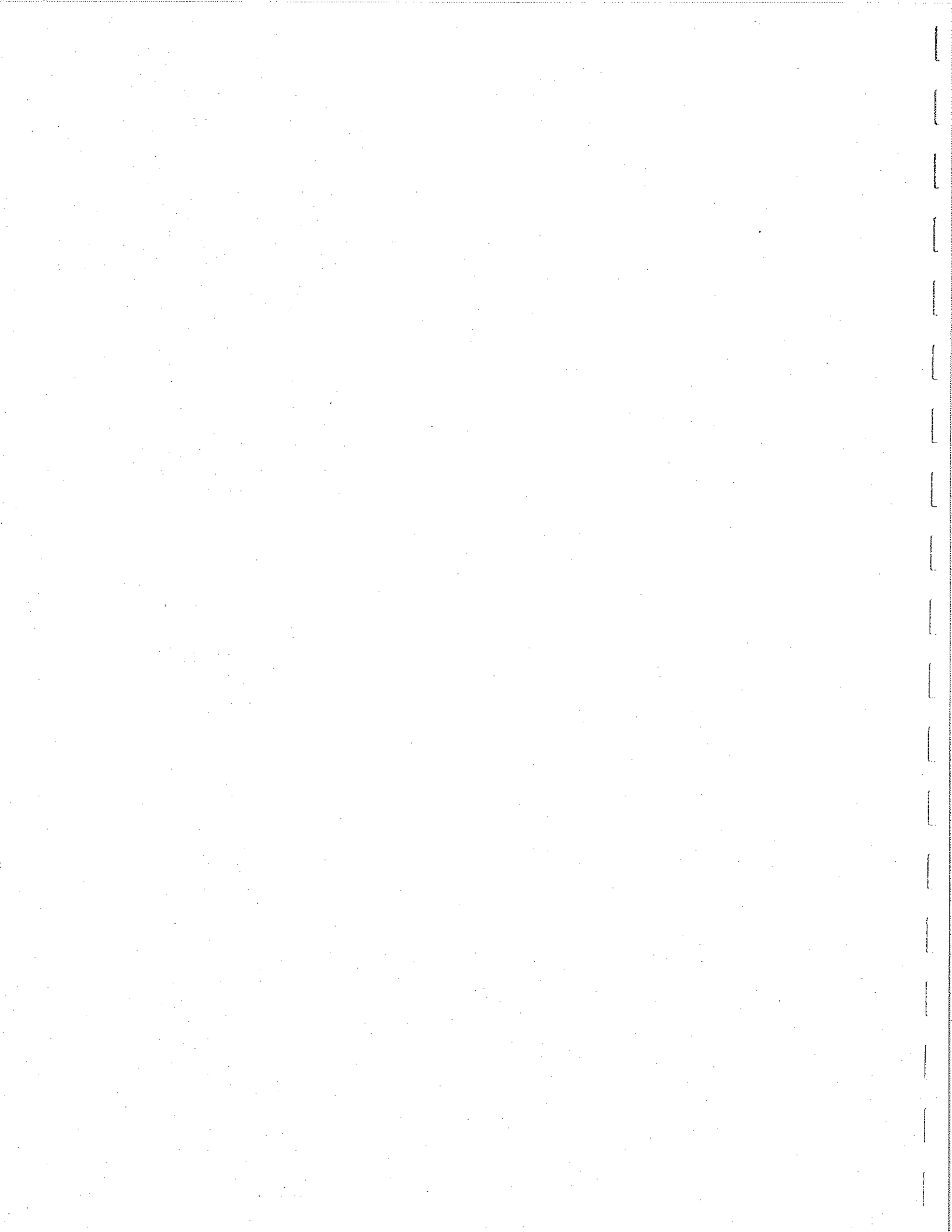

SECTION 5 REMOTE METERING PANEL

NOTE: Before proceeding, review sections 3 and 4 on the AM-19.

5.1 Installation

The RMP-19 Remote Metering Panel is designed to fulfill two different functions:

- a. A convenient extension of the meters on the AM-19 Monitor for use near the transmitter location.
- b. Remote Phase Monitor meters for installation at the studio as part of a complete remote control system.

In the first instance, since it is possible to use a multi-conductor cable for inter-connection, the remote meters will indicate simultaneously, as do the meters on the AM-19. For this purpose, connect terminals 2, 3, and 4 on the RMP-19 to terminals 32, 29, and 14, respectively, of plug J1 on the AM-19. To adjust the remote meters so that they agree with the local meters, use controls R6 and R7 on the rear panel of the AM-19 for the PHASE ANGLE and LOOP CURRENT meters, respectively.

When the RMP-19 is to be used as part of a complete remote control system, it is important that the rules and regulations of the F.C.C. be consulted regarding this type of operation. Advice on this subject may also be obtained from Potomac Instruments, inc.

For remote operation of the Phase Monitor, the tower selector relays must be operated from the transmitter unit of the remote control system, and selection must be made between the phase angle and loop current outputs, for each tower. Several methods which accomplish these functions are described in the section of this manual which covers the RSA-19 Remote Switching Adapter.

The method of extending the phase angle and loop current meter readings to the remote location will depend upon the type of remote control system in use. For DC systems, the metering voltages can be applied directly to the telephone lines. However, if there are series diodes present in the metering lines, it will be necessary to determine if they affect the linearity and accuracy of the monitor readings for the minimum values.

Figure 11-12 is the schematic diagram for the RMP-19. Two modes of operation are possible with this circuit:

- a. The meters may be selected by energizing relay K1 from the "raise-lower" switch in the studio unit. This method is used when one position on the stepping switch must be used for both phase angle and loop current to conserve stepper positions.
- b. The meters may be selected in sequence, as the towers are dialed.

For example, with a three-tower array, six dial positions would be assigned; three for phase angle (if it is desired to check the zero phase reading for the reference tower), and three for loop current. With this method, transfer relay K1 is not required, and the meters are connected directly to the stepping switch.

For the mode described in (a) above, it will be necessary to advise Potomac Instruments, inc. of the type of remote control system with which the RMP-19 will be used, so that the correct relay for K1 can be installed. One method of operation is shown in the RSA-19 section of this manual. The relay operates from the same voltage which is applied to the line for "raise-lower" operation. In some systems, a differential voltage method is used, whereby a low voltage is applied to the control line to energize the "lower" circuits, and a high voltage energizes the "raise" circuits. Relay K1 can be selected to operate in a differential mode of this type.

5.2 Calibration

Adjustment of the meters on the RMP-19 is accomplished at the AM-19 Monitor as follows:

1. Calibrate the remote control system to provide the normal value of total metering loop resistance.
2. Dial up the phase angle mode for the highest reading tower, and adjust R6 on the rear panel of the AM-19 so that the remote PHASE ANGLE meter reads the same as the local meter.
3. Dial up the loop current mode for the reference tower, and adjust R7 on the AM-19 so that the remote and local meters agree.
4. Check the phase angle and loop current readings on the remaining towers. If the remote indications do not agree with the local meters for the lower values, noise in the metering line may be a factor, and filtering will be required.

5.3 Operation

To set up the monitoring system for remote operation, the AM-19 RMT (remote) switch is depressed. This prevents the AM-19 TOWER and MODE switches from being energized locally. When these functions are selected from the remote position, the corresponding switch will be illuminated, indicating the status of the monitor to anyone in the transmitter location. Local control of the monitor is obtained by depressing the RMT switch once again, which releases it.

For installations where relay K1 is used for meter transfer, operation of the system consists of dialing the number which corresponds to the tower to be measured, and operating the "raise" position to read loop current on the remote LOOP CURRENT meter, and in the "lower" position to read phase angle on the PHASE ANGLE meter.

Where sequential dial positions are used, it is only necessary to operate the "raise-lower" switch in whichever mode has been connected to energize the tower relays.

SECTION 8 REMOTE SWITCHING ADAPTER, RSA-19

NOTE: Before proceeding, review sections 3, 4 and 5.

8.1 Installation

The RSA-19 Remote Switching Adapter may be required to interconnect the remote control system with the Type 19 Phase Monitor. It serves three purposes:

- a. It allows the monitor relays to be energized by whatever control voltage is utilized in the remote control system.
- b. It provides a method of automatically transferring the monitor between the DAY, CRITICAL HOURS, and NIGHT modes in a multi-pattern installation.
- c. It isolates the metering circuitry in the monitor from the external wiring during the time that the monitor is not being energized through the remote control system.

Figure 11-13 is a typical schematic for the installation of a RSA-19 in a 4-tower system. The RMP-19 Remote Metering Panel is an often utilized accessory and its installation and operation is described in section 5 of this manual.

Relays are installed in the RSA-19 at the factory in the required quantity with the coil voltage being determined by the "raise-lower" control voltage in the remote control system. (When used with remote control systems manufactured by Gates Radio Company, the RSA-19 configuration is revised to use one six-volt relay and two control relays at each tower position. Interconnection information will be supplied with the unit.)

The circuit of figure 11-13 is used when it is necessary to conserve dialing positions. The measurements for both phase angle and loop current are fed to the metering line through the same dial position with transfer between the two being accomplished by the "raise-lower" circuit in the remote control system. The drawing illustrates a typical connection for a 4-tower DA-3 array providing tower switching, pattern switching, meter switching, and automatic "release" of all monitor relays when the monitor is not under interrogation.

This system utilizes the "raise-lower" contact closures provided by many modern remote control systems. With the appropriate channel selected, the operator depresses (and holds) the "raise" switch energizing relay K1 and selecting tower 1 and the "ratio" output of the monitor. (The DAY, NIGHT or CRIT HRS mode is determined by the phasor switching.) In order to read PHASE, the operator depresses (and holds) the "lower" switch (energizing relay K2) for as long as necessary to make the reading. When neither the "raise" or "lower" function is activated, the monitor is in a release capacity awaiting the next command. The process is repeated at each dial position for the remaining towers.

Operating the "raise-lower" switch on the studio unit to perform the above functions also energizes or de-energizes the transfer relay on the RMP-19 so that the correct remote meter is across the line. More information about this operation is presented in section 5 of the manual which covers the RMP-19.

Figure 11-13 also shows how the DAY, NIGHT, CRIT HRS mode selection is made when operating by remote control. One set of contacts on each relay in the RSA-19 assembly applies -24 volts to the day or night mode relay through a set of transfer contacts in the phasor control system. Thus the appropriate mode relay will be energized, depending on the status of the phasor, each time a tower is selected. At the completion of the run-down, all relays in the AM-19 and RSA-19 will be de-energized, disconnecting the active circuitry in the AM-19 from the sampling lines.

This interface scheme is sufficiently flexible to accommodate remote control systems which supply voltages for Raise and Lower command. Since the KHPDII series relays are available in a variety of operating voltages, appropriate relays may be selected corresponding to the command voltage. Additional towers are accommodated by simply expanding the switching system as necessary.

8.2 Calibration

Calibration for the overall remote system is covered in section 5 on the RMP-19.

8.3 Operation

Operation of the system has been described in par. 8.1 above and in section 5 on the RMP-19.

SECTION 9 MAINTENANCE

9.1 General

The Type 19 System has been designed and produced with the highest quality components and will provide many years of reliable service. To maintain specified performance, the monitor should normally require only a periodic check of the adjustments described in the Calibration sections of this manual. However, a component may occasionally fail and the purpose of this section is to provide a guide for the rapid isolation and repair of the more commonly encountered difficulties.

Some repairs should be made at the factory. However, many failures can be serviced in the field, and Potomac Instruments should be contacted for advice in diagnosing a problem before the monitor is removed from the installation.

In most instances replacement parts or modules can be obtained from the factory on short notice.

9.2 Trouble Shooting

To properly trouble shoot this equipment it is essential to have a thorough understanding of the function and operation of the circuitry, and it is strongly recommended that the appropriate sections of this manual on Theory, Calibration, and Operation be reviewed before proceeding.

NOTE: The Type 19 Antenna Monitor utilizes mercury wetted reed relays for many switching functions. The mercury in these units will sometimes flow and close the relay contacts when the monitor chassis is inclined by more than approximately 30 degrees. The monitor may be operated in any position without causing damage, but this effect should be kept in mind when "tipping" the unit during servicing. On occasion a new or recently handled relay may need to be energized once or twice to remove mercury beads from the contacts.

Experience has shown that most antenna monitor problems are traced to the sampling system. For this reason it is important to measure and record the normal sampling line voltage at the monitor input after the array is properly adjusted. These measurements will be useful in detecting trouble with sampling loops, transmission lines or associated connectors. Other tests which can be easily made include the following:

1. Measure the input termination resistance.
2. Measure the power supply voltages - check fuse.
3. Check that all plug-in modules are properly seated.
4. Check for loose relays.

5. Use one sampling line to check all inputs while monitoring the LOOP CURRENT meter.
6. Check the phasing capacitor.
7. Check the current detector diode.

9.3 Power Supply

The AM-19 includes three power supplies: +12.5 volts DC and -12.5 volts DC regulated supplies for all solid state circuitry, and an unregulated 24 volt DC supply for operation of the relays and push button lamps.

The power supply voltage may be conveniently checked at pin 19 (+12.5V), pin 20 (-12.5V) or between pins 23 and 24 (24V) of either J1 or J2.

CAUTION: Never connect the voltmeter ground lead to the 24 volt common (pin 23) or pins 19 and 20, as this will short circuit the power supply.

The AM-19 is protected with a rear panel fuse, however, because the POWER switch controls the AC power to other units of the Type 19 System, the red POWER light remains energized when the fuse is blown.

9.4 Relay Replacement

In most cases erratic operation of the monitor can be traced to a loose or defective relay. On some models the reed relays are mounted in pin sockets and can be easily replaced. The relays on the AM-19 and PMA-19 input modules can be plugged-in with the aid of a pair of long-nosed pliers to position the relays and a large screwdriver to completely seat the units into the sockets.

NOTE: Mercury wetted relays must be installed with the arrow pointing upwards, otherwise the mercury will envelop and permanently close the contacts.

9.5 Servicing Input Modules

An input module can be unmounted for servicing without cutting the buss wires as follows:

1. Remove the mounting screws for the module to be serviced and also for at least two adjacent modules on each side.
2. Unsolder the buss wires one at a time and pull them out of the slots on the edge of the module printed circuit board. (Unfastening the adjacent modules will allow enough slack in the buss wires to accomplish this.)
3. Rotate the module upward from between the other modules to allow removal of the printed circuit board for replacement of components.
4. If the module must be removed completely, it will be necessary to unsolder the color-coded wires.

9.6 Replacing Current Detector Diode

With RF voltage on the tower current buss (Terminal 11, BD-6) there should be at least 0.5 volts DC output from the current detector (terminal 10, BD-6 brown & white wire). If not, the current detector diode may have been damaged by sampling line transients from lightning or other causes. The current detector diode is usually located in the right-most input module (viewing the rear of the monitor) and is plugged into pin sockets on the printed circuit board. Using long-nosed pliers remove the diode and test with an ohmmeter. If defective, replace with the same type diode being careful not to ground the diode leads by pushing too far through the pin sockets.

9.7 Digital Voltmeter

The digital voltmeter used in the PMA-19 is covered in detail in the United Systems model 252/252-1 instruction book.

The DVM is modified by Potomac Instruments for this application. These modifications consist of removing the RANGE switch, transferring the ZERO and CALibration potentiometer to the PMA-19 cal panel, and providing relay control of the DVM zero and calibration functions.

If difficulties are experienced in calibrating the DVM, check the push button switches (S2 and S3) on the PMA-19 cal-panel and the DVM zero and cal relays. Also check that the DVM connector (P2) is properly seated. Most NIXIE tube problems are traceable to defective plug-in integrated circuits which are readily accessible through the top of the chassis. The DVM is easily removed from the PMA-19 chassis by unplugging P2 and P3 and removing the hardware which fastens the DVM mounting rails to the chassis and panel.

NOTE: Do not energize the DVM unless P2 is plugged into J2.

When DVM difficulties cannot be corrected in the field, the unit should be returned to Potomac Instruments. If necessary, a substitute DVM can be provided by PI during the repair interim.

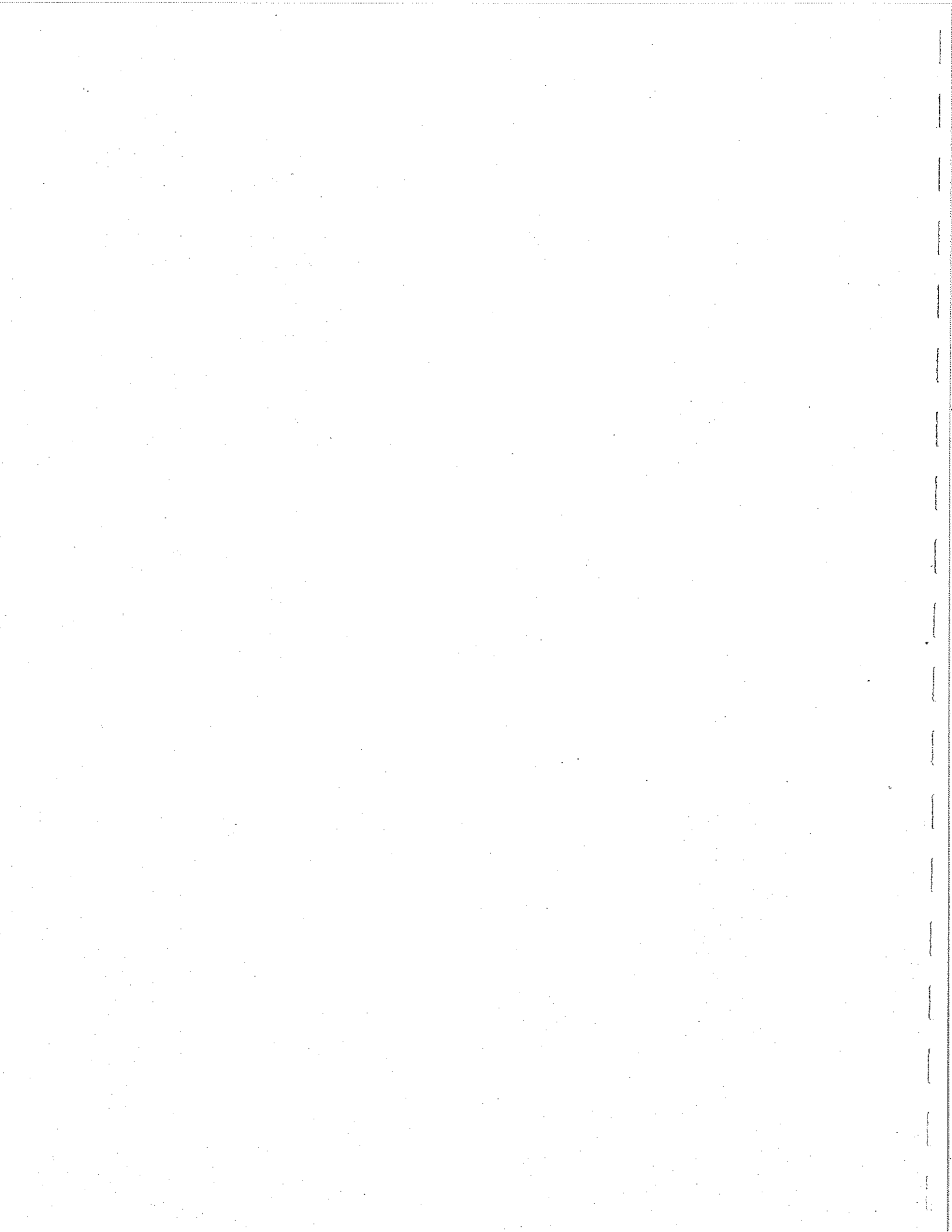

SECTION 10 REPLACEABLE PARTS

10.1 General

This section contains the lists of replaceable parts for the equipment covered in this manual.

A manufacturer is referenced for most components. However, parts with an EIA registered type number (1N, 2N, 3N . . .) or a military number (RN, DM . . .) can be obtained from any source offering the same numbered device. Also, certain integrated circuits which are functionally interchangeable are available under different manufacturer's type numbers.

When ordering replacement parts from Potomac Instruments, specify the name, model and serial number of the equipment, and the reference designation, description and part number of each item.

Table 10-1 is an index of the replaceable parts lists for the major sub-assemblies comprising each equipment.

Table 10-1 Index of Replaceable Parts

Table No.	AM-19 Sub-assemblies	Page
10-2	AM-19 Antenna Monitor, Main Chassis	10-2
10-3	AM-19 Input Module	10-5
10-4	Limiter Module	10-6
10-5	Phase Detector Module	10-8
10-6	Current Meter Module	10-10
10-7	Power Regulator Module	10-12
	
10-12	RMP-19 Remote Metering Panel	10-21

Table 10-2 Replaceable Parts, AM-19 Antenna Monitor, Main Chassis

<u>Reference Designation</u>	<u>Description</u>	<u>Manufacturer, Part Number</u>
C1, 2	Capacitor, ceramic .01 μ f, 125V DC	Sprague 125L-S10
C3, 4, 5	Capacitor, electrolytic 500 μ f, -10%, +150%, 50V	Mallory WP-065
C6	Capacitor, dipped mica, 24pf, 5%, 500V	Arco-Elmenco DM-15-240J
C7	Capacitor, variable 4.5 to 50pf	Hammarlund MAPC-50
C8	Capacitor, ceramic 1.0 μ f, 20%, 50V	Sprague 5C023105X0500B3
CR1	Diode, silicon	GE, IN5059
CR2	Diode, zener	Motorola, IN2970B
F1	Fuse, 0.5 amp, Slo Blo	Littelfuse, 313.500
FT1, 2, 3	Feedthru terminal, Teflon	Selectro, FT-1000
J1	Connector, socket 33 contact	Cinch-Jones S-333-DB
J2	Connector, socket 27 contact	Cinch-Jones S-327-DB
J3 thru J7	Connector, PC board, 15 contact	Amphenol 225-21521-101
J8	Connector, phone jack	Switchcraft, 11
L1, 2	Choke, line filter 100 μ H, 20%	J. W. Miller 5250
M1	Meter, PHASE ANGLE, 0 to 100 μ A DC, 0.5% tracking	Potomac Instruments dwg. no. B-20061
M2	Meter, LOOP CURRENT, 0 to 100 μ A DC, 0.5% tracking	Potomac Instruments dwg. no. B-1001-2

Table 10-2 Continued

<u>Reference Designation</u>	<u>Description</u>	<u>Manufacturer, Part Number</u>
P1	Connector, AC plug, 3 conductor	Harvey Hubbell 7486
Q1, 2	Transistor, silicon PNP	RCA, 2N3054 with insulator KA21A-100-DF31A
R1	Resistor, composition, 12K, 5%, $\frac{1}{4}$ w	RCO7GF123J
R2	Potentiometer, 2K, 10%, .75w	Beckman Helipot 78SR2K
R3	Potentiometer, 500 ohms, 10%, .75w	Beckman Helipot 78SR500
R4, 5 (Deleted in Serial No. 166 and above)	Potentiometer, 5K, 10%, 1w	Bourns 3025S-1-502M
R6, 7	Potentiometer, 10K, 10%, .75w	Beckman Helipot 78SR10K
R8, 9, 10	Potentiometer, 10 turn 20K, 5%, 2w	Beckman Helipot 7246R20K
R11	Resistor, composition, 22K, 5%, $\frac{1}{4}$ w	RCO7GF223J
R12, 13	Resistor, composition, 47K, 5%, $\frac{1}{4}$ w	RCO7GF473J
S1 thru S12	Switch, lighted push-button, green	Clare-Pendar S180-11-F4/CL48-0A-(G2-P)/B387
S13	Switch, lighted push-button, black	Clare-Pendar S180-11-F4/CL48-0A-ZZ/B387
S14	Switch, lighted push-button, red	Clare-Pendar S181-11-F4/CL48-0A-RR/A1H
S15, 16	Switch, push-button	Switchcraft, DA-02-3
S17	Switch, lighted push-button, white	Clare-Pendar S180-11-F4/CL48-0A-WW/B387
S18	Switch, lighted push-button, orange	Clare-Pendar S180-11-F4/CL48-0A-KK/B387
S19	Switch, lighted push-button, blue	Clare-Pendar S180-11-F4/CL48-0A-(B5P)/B387

Table 10-2 Continued

<u>Reference Designation</u>	<u>Description</u>	<u>Manufacturer, Part Number</u>
S20	Switch, lighted push-button, yellow	Clare-Pendar S221-33-F4/C148-OA-YY/B387
T1	Power Transformer	UTC, H-143
Mates with J1	Connector, plug, 33 contact	Cinch-Jones, P-333-OCT
Mates with P1, Part of power cord	Connector, AC socket, 3 conductor	Harvey Hubbell 7484
Quantity 1	Power cord set, 3 conductor	Belden 17406-SJ
Quantity 2	Socket, transistor, TO-66	Robinson-Nugent, MP-66302
Quantity 3	Dial, 10 turn	IRC, RD-412
Quantity 1	Fuseholder	Bussman, HKP

Table 10-3 Replaceable Parts, AM-19 Input Module

<u>Reference Designation</u>	<u>Description</u>	<u>Manufacturer, Part Number</u>
BD-6	Printed circuit board	Potomac Instruments
C1	Capacitor, film, .001 μ f, 10%, 80V	Sprague 192P1029R8
C2, 3	Capacitor, tantalum, 4.7 μ f, 10%, 35V	Sprague 150D475x9035B2
CRL, 2, 4	Diode, silicon	GE, IN5059
CR3	Diode, germanium	Sylvania, IN277
K1, 2	Relay, mercury wetted reed, SPST NO	Magnecraft 131PCX-39
K3	Relay, mercury wetted reed, DPST NO	Magnecraft W131PCX-40
L1	Inductor, 10mH, 10%	Nytronics, SWD-10,000
R1	Resistor, non-inductive wire wound, 1%, 10w	Dale PH-10-5
R2, 6	Resistor, composition, 470 ohms, 5%, $\frac{1}{4}$ w	RCO7GF471J
R3, 7	Resistor, composition, 2.2K, 5%, $\frac{1}{4}$ w	RCO7GF222J
R4, 10	Resistor, non-inductive wire wound, 100 ohms, 1%, $\frac{1}{2}$ w	Dale NS- $\frac{1}{2}$
R5, 9	Resistor, non-inductive wire wound, 620 ohms, 1%, 2w	Dale NS-2
R8	Resistor, wire wound 200 ohms, 1%, 2w	Dale RS-2
R11	Resistor, wire wound 470 ohms, 1%, $\frac{1}{2}$ w	Dale RS- $\frac{1}{2}$
R12, 13	Resistor, composition, 100K, 5%, $\frac{1}{4}$ w	RCO7GF104J
SCR1, 2	Silicon controlled rectifier	GE, C6A
Quantity 2	SCR socket, 3 lead, TO-5	Robinson-Nugent, SP-5173

Table 10-4 Replaceable Parts, Limiter Module

<u>Reference Designation</u>	<u>Description</u>	<u>Manufacturer, Part Number</u>
A1, A2	Integrated Circuit	RCA, CA3028B
BD-8	Printed circuit board	Potomac Instruments
C1 thru C7	Capacitor, film, 0.1 μ f, 10%, 80V	Sprague 192F1049R8
C8	Capacitor, mica dipped, 270pf, 5%, 300V	Arco-Elmenco DM-15 271J
CR1, 2	Diode, silicon	GE, IN4606
CR3	Diode, silicon	GE, IN4154
CR4	Diode, zener	Motorola, IN752A
L1	Inductor 470 μ H, 10%	Nytronics SWD-470
L2, 3	Inductor 0.33 μ H, 10%	Nytronics DD-0.33
L4	Inductor 10mH, 10%	Nytronics SWD-10,000
Q1 thru Q4	Transistor, silicon NPN	Motorola, 2N3904
R1, 23, 24	Resistor, composition, 560 ohms, 5%, $\frac{1}{4}$ w	RCO7GF561J
R2	Resistor, composition, 47 ohms, 5%, $\frac{1}{2}$ w	RC20GF470J
R3, 4, 30	Resistor, composition, 10 ohms, 5%, $\frac{1}{4}$ w	RCO7GF
R5, 18, 25, 26, 28	Resistor, composition, 470 ohms, 5%, $\frac{1}{4}$ w	RCO7GF471J
R6	Resistor, composition, 100 ohms, 5%, $\frac{1}{4}$ w	RCO7GF101J
R7	Resistor, composition, 56 ohms, 5%, $\frac{1}{4}$ w	RCO7GF560J

Table 10-4 Continued

<u>Reference Designation</u>	<u>Description</u>	<u>Manufacturer, Part Number</u>
R8 (Deleted in Serial No. 166 and above)	Resistor, metal glaze, 100K, 2%, $\frac{1}{4}$ w	RG07S104G
R9	Resistor, metal glaze, 100K, 2%, $\frac{1}{4}$ w	RG07S104G
R10	Resistor, variable, 5K, 10%, .75w	Beckman Helipot 76PR5K
R11, 12, 20, 21	Resistor, metal glaze, 330 ohms, 2%, $\frac{1}{4}$ w	RG07S331G
R13, 14	Resistor, composition, 82 ohms, 5%, $\frac{1}{4}$ w	RC07GF820J
R15, 16	Resistor, composition, 680 ohms, 5%, $\frac{1}{4}$ w	RC07GF681J
R17, 29	Resistor, composition, 27 ohms, 5%, $\frac{1}{4}$ w	RC07GF270J
R19	Resistor, composition, 220 ohms, 5%, $\frac{1}{4}$ w	RC07GF221J
R22	Resistor, composition, 330 ohms, 5%, $\frac{1}{4}$ w	RC07GF331J
R27	Resistor, composition, 1K, 5%, $\frac{1}{4}$ w	RC07GF102J
Quantity 2	IC socket, 8 lead, TO-5	Robinson-Nugent DP 5178
TP1	Test point, green	E. F. Johnson, 105-754
TP2	Test point, brown	E. F. Johnson, 105-758

Table 10-5 Replaceable Parts, Phase Detector Module

<u>Reference Designation</u>	<u>Description</u>	<u>Manufacturer, Part Number</u>
A1	Integrated circuit	Motorola, MCL709CG
BD-7	Printed circuit board	Potomac Instruments
C1, 2, 5, 6, 9	Capacitor, film, 0.1 μ f, 10%, 80V	Sprague 192P1049R8
C3, 4, 10	Capacitor, film, 0.01 μ f, 10%, 80V	Sprague 192P1039R8
C7	Capacitor, film, .0022 μ f, 10%, 80V	Sprague 192P2229R8
C8	Capacitor, 100pf	Arco, DM-15-101J
C11 thru C16	Capacitor, disc, .001 μ f, 20%, 1000V	Erie CK60AW102M
CR1	Diode, reference	Motorola, IN823
CR2	Diode, zener	Motorola, IN748A
CR3, 4, 5, 6, 7	Diode, silicon	GE, IN4154
L1	Inductor, 100 μ H, 10%	Nytronics, SWD-100
Q1 thru Q6	Transistor	2N2708
Q7 thru Q10	Transistor	Motorola, 2N5089
R1, 3, 5, 7, 10, 11, 12, 14, 15, 16, 33	Resistor, composition, 10 ohms, 5%, $\frac{1}{4}$ W	RCO7GF100J
R2, 4, 6, 8	Resistor, composition, 82 ohms, 5%, $\frac{1}{4}$ W	RCO7GF820J
R9, 13	Resistor, composition, 270 ohms, 5%, $\frac{1}{4}$ W	RCO7GF271J
R17, 18	Resistor, composition, 150 ohms, 5%, $\frac{1}{4}$ W	RCO7GF151J
R19, 31	Resistor, metal film, 1.00K, 1%, $\frac{1}{4}$ W	RN65C1001F

Table 10-5 Continued

<u>Reference Designation</u>	<u>Description</u>	<u>Manufacturer, Part Number</u>
R20	Resistor, metal film, 1.21K, 1%, $\frac{1}{4}$ W	RN65C1211F
R21	Resistor, metal film, 2.67K, 1%, $\frac{1}{4}$ W	RN65C2671F
R22	Resistor, metal film, 1.33K, 1%, $\frac{1}{4}$ W	RN65C1331K
R23, 25, 27	Resistor, metal film, 590 ohms, 1%, $\frac{1}{4}$ W	RN65C5900F
R24, 26, 28	Resistor, metal film, 2.43K, 1%, $\frac{1}{4}$ W	RN65C2431F
R29	Resistor, metal glaze, 620 ohms, 2%, $\frac{1}{4}$ W	RG07S621G
R30	Resistor, metal film, 316 ohms, 1%, $\frac{1}{4}$ W	RN65C3160F
R32	Resistor, metal film, 249 ohms, 1%, $\frac{1}{4}$ W	RN65C2490F
R34, 35	Resistor, metal film, 2.74K, 1%, $\frac{1}{4}$ W	RN65C2741F
R36, 37, 40	Resistor, metal film, 5.36K, 1%, $\frac{1}{4}$ W	RN65C5361F
R38	Resistor, composition, 1.5K, 5%, $\frac{1}{4}$ W	RCO7GF152J
R39	Resistor, composition, 220 ohms, 5%, $\frac{1}{4}$ W	RCO7GF221J
R41	Resistor, metal film, 52.3K, 1%, $\frac{1}{4}$ W	RN65C5232F
TP1	Test point, yellow	E. F. Johnson Co., 105-757
TP2	Test point, orange	E. F. Johnson Co., 105-756
Quantity 1	IC socket, 8 lead, TO-5	Robinson-Nugent, DP-5178

Table 10-6 Replaceable Parts, Current Meter Module

<u>Reference Designation</u>	<u>Description</u>	<u>Manufacturer, Part Number</u>
A1	Integrated circuit	Motorola, MCL7909CG
A2	Rectifier assembly	Mallory, FW-100
BD-9	Printed circuit board	Potomac Instruments
C1	Capacitor, dipped mica, 120pf, 5%, 500V	Arco-Elmenco DM-15-121J
C2	Capacitor, film, .0047 μ f, 10%, 80V	Sprague 192P47292R8
C3	Capacitor, tantalum, 10 μ f, 10%, 20V	Sprague 150D106X9020B2
C4	Capacitor, dipped mica, 220pf, 5%, 500V	Arco-Elmenco DM-15-221J
C5	Capacitor, tantalum, 33 μ f, 10%, 20V	Sprague 150D336X9020R2
C6	Capacitor, tantalum, 150 μ f, 20%, 15V	Sprague 150D157X9015S2
C7, 8	Capacitor, film, 0.1 μ f, 10%, 80V	Sprague 192P1049R8
C9	Capacitor, film, .01 μ f, 10%, 80V	Sprague 192P1039R8
CR1, 2	Diode, silicon	GE, IN4154
Q1	Transistor, silicon PNP	Motorola, 2N2904
R1, R19	Resistor, composition, 560K, 5%, $\frac{1}{4}$ w	RC07GF564J
R2	Resistor, metal glaze, 15K, 2%, $\frac{1}{4}$ w	RG07S153G
R3	Resistor, metal glaze 6.8K, 2%, $\frac{1}{4}$ w	RG07S682G
R4	Resistor, metal glaze 220K, 2%, $\frac{1}{2}$ w	RG20S220G
R5	Resistor, composition, 2.2M, 5%, $\frac{1}{4}$ w	RC07GF225J

Table 10-6 Continued

<u>Reference Designation</u>	<u>Description</u>	<u>Manufacturer, Part Number</u>
R6	Resistor, metal glaze, DA-1: 10.0K, 1%, $\frac{1}{4}$ w DA-2: 20.0K, 1%, $\frac{1}{4}$ w DA-3: not used	RN65C1002F RN65C2002F
R7	Potentiometer, 5K, 10%, .75w	Beckman Helipot 76PR5K
R8	Resistor, metal glaze, 2.2K, 2%, $\frac{1}{4}$ w	RG07S222G
R9	Resistor, metal film, 2.21K, 1%, $\frac{1}{4}$ w	RN65C2211F
R10	Resistor, composition, 390 ohms, 5%, $\frac{1}{4}$ w	RC07GF391J
R11	Resistor, metal film, 11.5K, 1%, $\frac{1}{4}$ w	RN65C1152F
R12	Resistor, composition, 1.5K, 5%, $\frac{1}{4}$ w	RC07GF152J
R13	Resistor, composition, 1K, 5%, $\frac{1}{4}$ w	RC07GF102J
R14	Resistor, metal glaze, 620 ohms, 2%, $\frac{1}{4}$ w	RG07S621G
R15	Resistor, metal film, 52.3K, 1%, $\frac{1}{4}$ w	RN65C5232F
R16	Resistor, metal film, 5.36K, 1%, $\frac{1}{4}$ w	RN65C5361F
R17	Resistor, composition, 220 ohms, 5%, $\frac{1}{4}$ w	RC07GF221J
R18	Resistor, composition, 10K, 5%, $\frac{1}{4}$ w	RC07GF103J
TP1	Test point, blue	E. F. Johnson, 105-760
TP2	Test point, white	E. F. Johnson, 105-751
Quantity 1	IC socket, 8 lead, TO-5	Robinson-Nugent, DP-5178

Table 10-7 Replaceable Parts, Power Regulator Module

<u>Reference Designation</u>	<u>Description</u>	<u>Manufacturer, Part Number</u>
BD-2	Printed circuit board	Potomac Instruments
C1, 2	Capacitor, tantalum, 22 μ f, 10%, 35V	Sprague 150D226X9035R2
C3, 4	Capacitor, film, 0.1 μ f, 10%, 80V	Sprague 192P1049R8
CRL, 2	Rectifier, silicon, bridge	Mallory, FW-100
CR3, 6	Diode, zener	Motorola, IN4733A
CR4, 5, 7, 8, 11, 12, 13, 14	Diode, silicon	Sylvania IN457
CR9, 10	Diode, reference	Motorola, IN823
Q1, 2	Transistor, silicon, PNP	Motorola, 2N2904
Q3 thru Q6	Transistor, silicon, NPN	Motorola, 2N2218
R1, 2	Resistor, composition, 2.2K, 5%, $\frac{1}{2}$ w	RC20GF222J
R3, 4	Resistor, composition, 680 ohms, 5%, $\frac{1}{2}$ w	RC20GF681J
R5, 6	Resistor, composition,	RC42GF150J
R7, 10	Potentiometer 200 ohms, 10%, .75w	Beckman Helipot 76PR200
R8, 9, 11, 12	Resistor, film, 1020 ohms, 1%, $\frac{1}{4}$ w	RN65B1021F
TP1	Test point, violet	E. F. Johnson, 105-762
TP2	Test point, red	E. F. Johnson, 105-752

Table 10-12 Replaceable Parts, Remote Metering Panel, RMP-19

<u>Reference Designation</u>	<u>Description</u>	<u>Manufacturer, Part Number</u>
K1	Relay, 4PDT, gold-flashed contacts, solenoid voltage selected for compatibility with remote control unit	Potter & Brumfield KHP 17-series 12V DC: D11-12 24V DC: D11-24 48V DC: D11-48 120V AC: A11-120
M1	Meter, PHASE ANGLE, 0 to 100 microamps DC, 0.5% tracking accuracy	Potomac Instruments dwg. no. B-20061
M2	Meter, LOOP CURRENT ratio, 0 to 100 microamps DC, 0.5% tracking accuracy	Potomac Instruments dwg. no. B-1001-2
R1, 2	Resistor, metal film, 33.2K, 1%, $\frac{1}{4}$ w	RN65C3322F
TB1	Terminal block, barrier, 6 terminals	Cinch-Jones 6-140-Y
Quantity 1	Relay socket with hold down spring	Potter & Brumfield 27E006/20C217

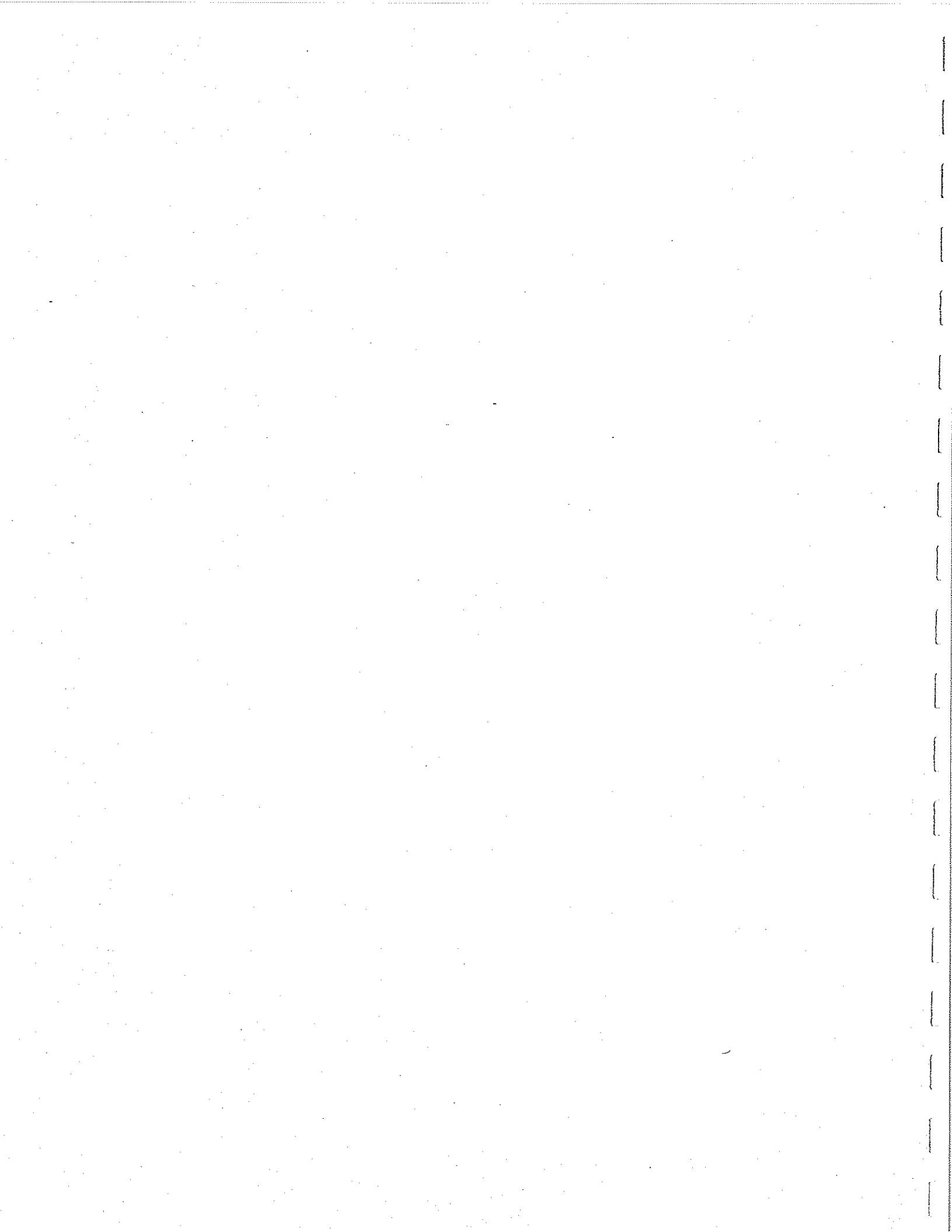

SECTION 11 SCHEMATIC DIAGRAMS

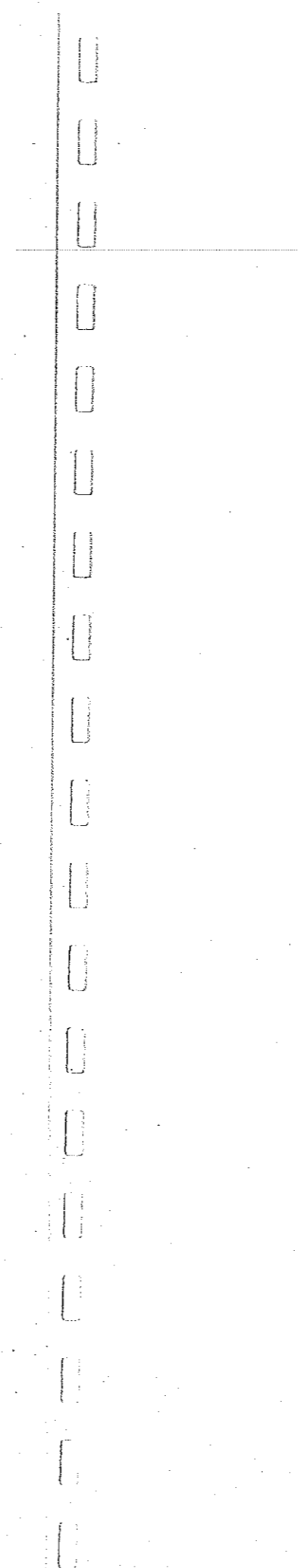

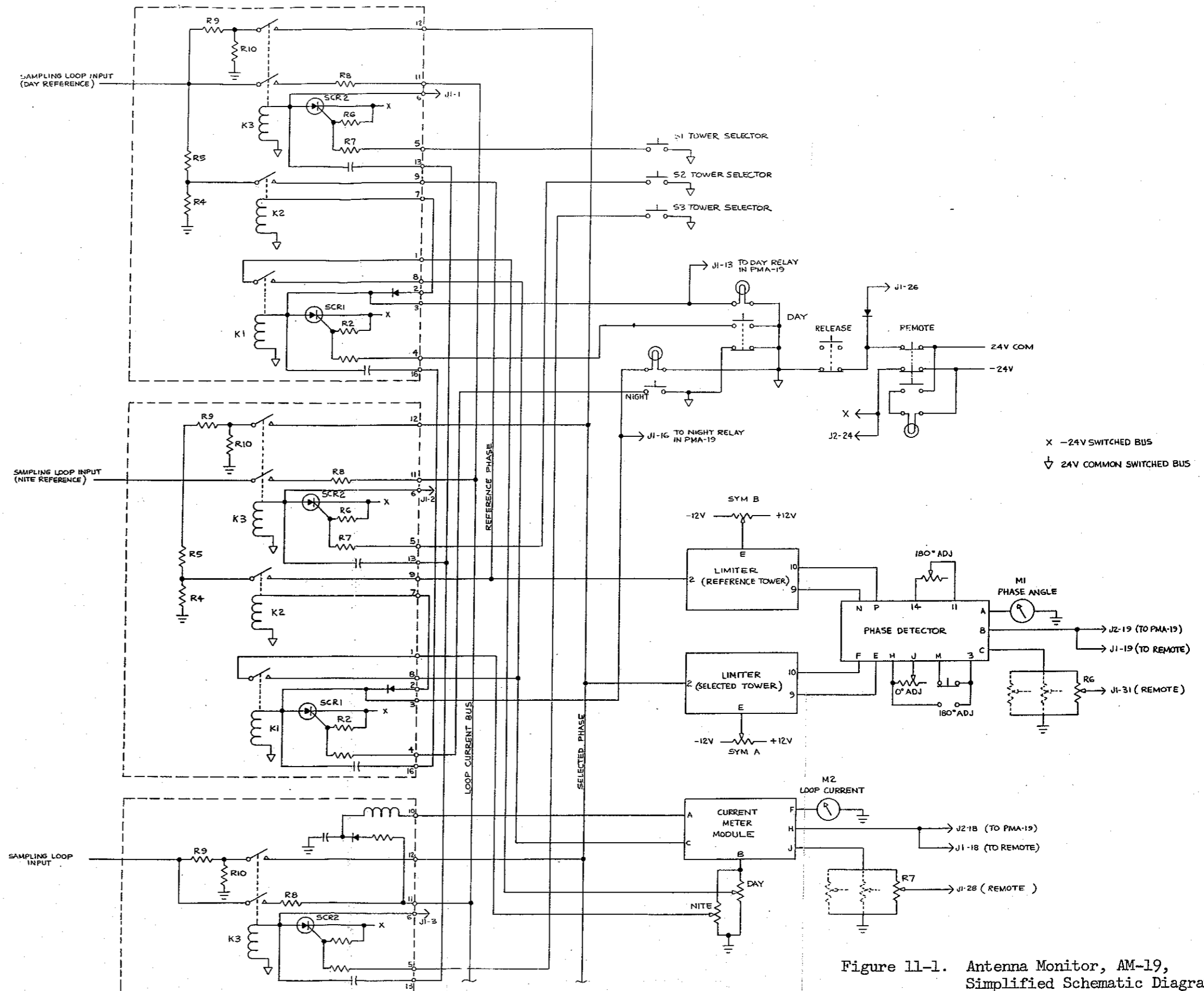
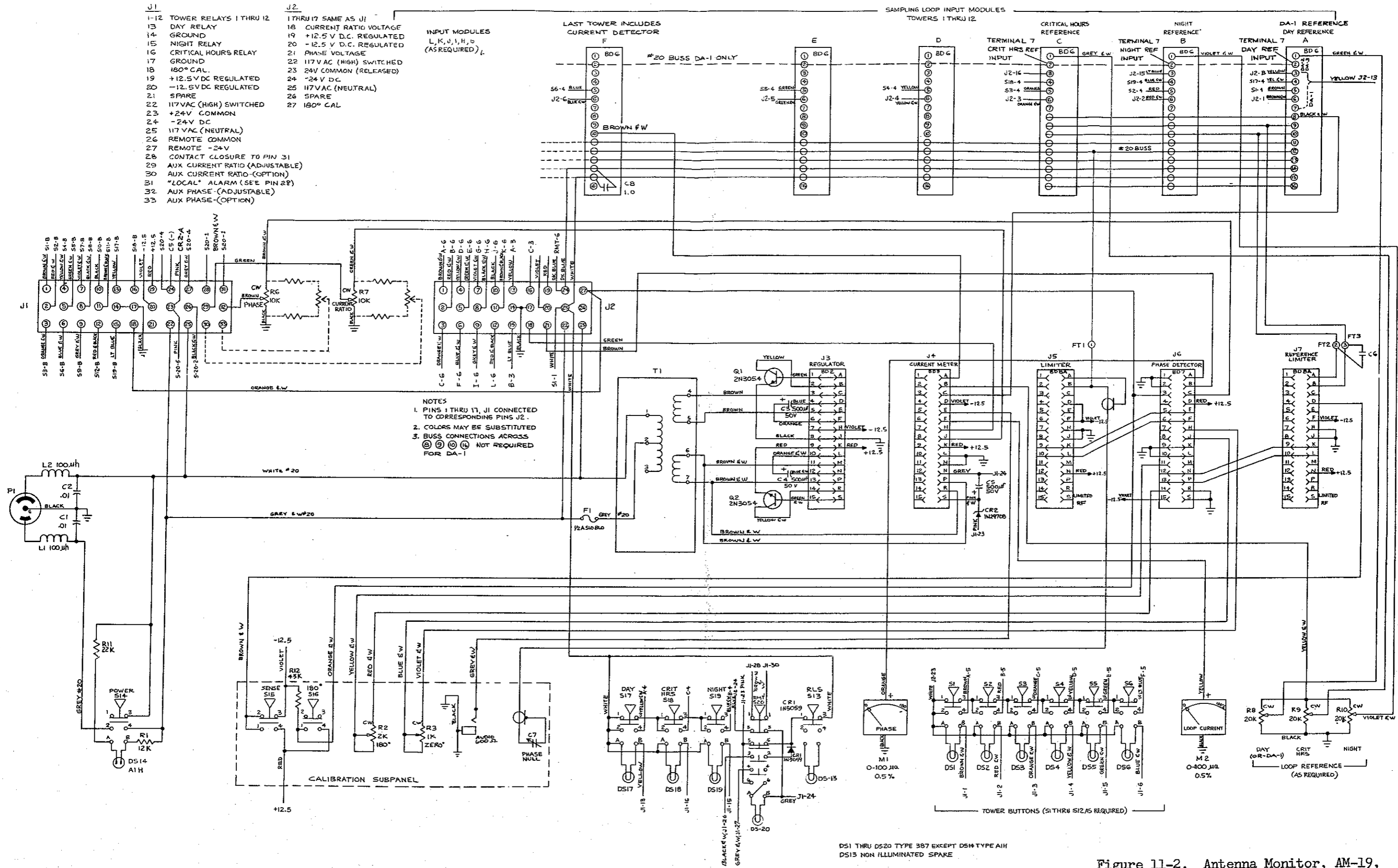

Figure 11-1. Antenna Monitor, AM-19, Simplified Schematic Diagram



- | | | | |
|-----------------------------------|-----------------------------|-----------|----------------------|
| J1 | 1-12 TOWER RELAYS 1 THRU 12 | J2 | 1 THRU 17 SAME AS J1 |
| 13 DAY RELAY | 18 CURRENT RATIO VOLTAGE | 18 | 18 |
| 14 GROUND | 19 +12.5 V D.C. REGULATED | 19 | 19 |
| 15 NIGHT RELAY | 20 -12.5 V D.C. REGULATED | 20 | 20 |
| 16 CRITICAL HOURS RELAY | 21 PHASE VOLTAGE | 21 | 21 |
| 17 GROUND | 22 117 V AC (HIGH) SWITCHED | 22 | 22 |
| 18 180° CAL. | 23 24V COMMON (RELEASED) | 23 | 23 |
| 19 +12.5V DC REGULATED | 24 -24V DC | 24 | 24 |
| 20 -12.5V DC REGULATED | 25 117V AC (NEUTRAL) | 25 | 25 |
| 21 SPARE | 26 SPARE | 26 | 26 |
| 22 117V AC (HIGH) SWITCHED | 27 180° CAL | 27 | 27 |
| 23 +24V COMMON | | | |
| 24 -24V DC | | | |
| 25 117V AC (NEUTRAL) | | | |
| 26 REMOTE COMMON | | | |
| 27 REMOTE -24V | | | |
| 28 CONTACT CLOSURE TO PIN 31 | | | |
| 29 AUX CURRENT RATIO (ADJUSTABLE) | | | |
| 30 AUX CURRENT RATIO (OPTION) | | | |
| 31 "LOCAL" ALARM (SEE PIN 28) | | | |
| 32 AUX PHASE (ADJUSTABLE) | | | |
| 33 AUX PHASE (OPTION) | | | |

INPUT MODULES
L, K, U, I, H, O
(AS REQUIRED) L

LAST TOWER INCLUDES
CURRENT DETECTOR

SAMPLING LOOP INPUT MODULES
TOWERS 1 THRU 12

CRITICAL HOURS
REFERENCE

NIGHT
REFERENCE

DA-1 REFERENCE
DAY REFERENCE

- NOTES
1. PINS 1 THRU 17, J1 CONNECTED TO CORRESPONDING PINS J2.
 2. COLORS MAY BE SUBSTITUTED
 3. BUSS CONNECTIONS ACROSS
Ⓢ Ⓣ Ⓤ Ⓥ NOT REQUIRED FOR DA-1

DS1 THRU DS20 TYPE 387 EXCEPT DS14 TYPE A1H
DS13 NON ILLUMINATED SPARE

Figure 11-2. Antenna Monitor, AM-19,
Main Chassis Schematic Diagram

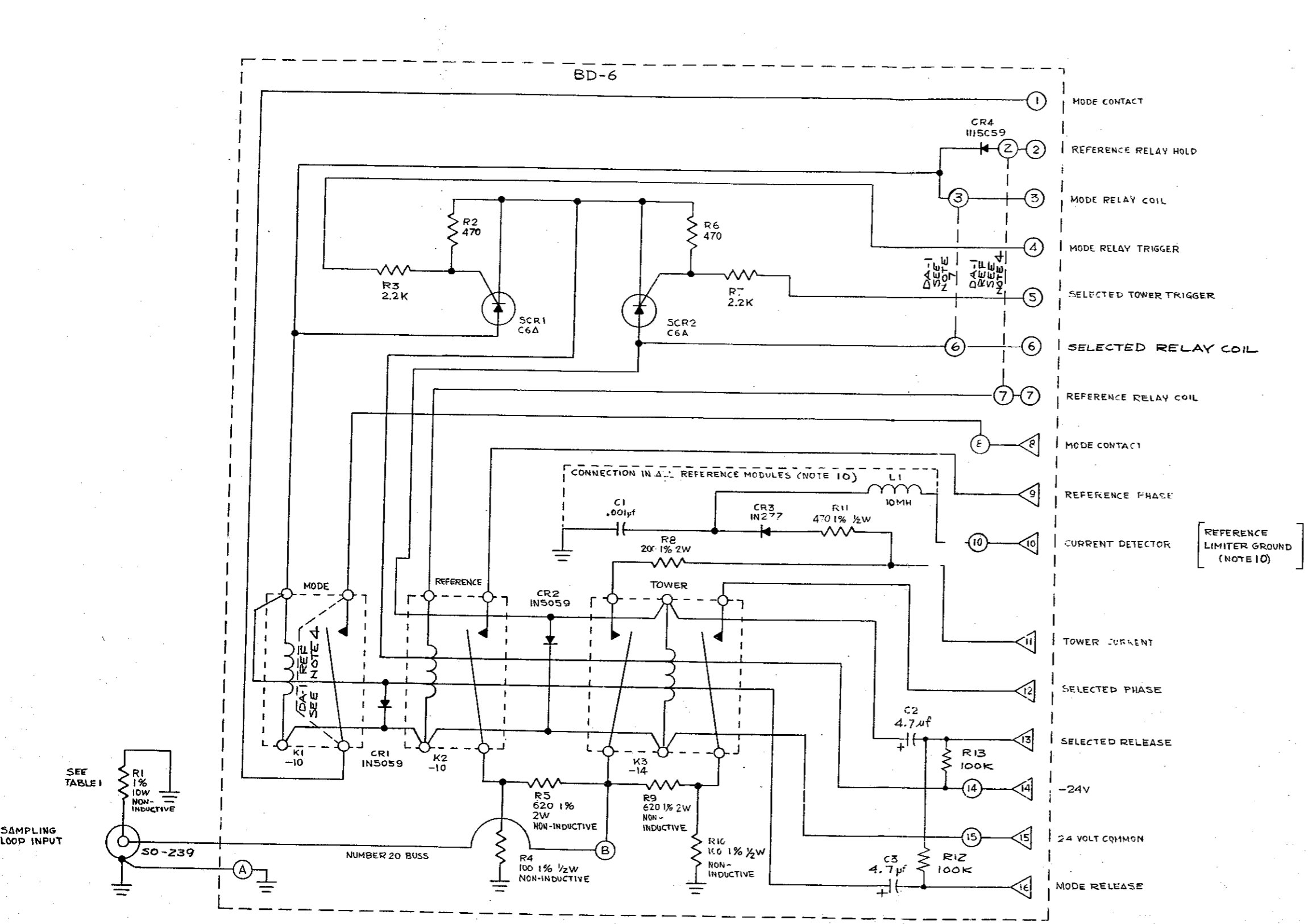

- NOTES:
1. \triangle # 20 BUSS \textcircled{N} = WIRE CONNECTION.
 2. UNLESS OTHERWISE INDICATED, ALL RESISTOR VALUES IN OHMS.
 3. C3, CR1, K1, R2, R3, R4, R5, AND SCR1 INCLUDED ONLY IN DA-2 AND DA-3 REFERENCE MODULES.
 4. CONNECTION IN PLACE OF K1 CONTACTS AND FROM $\textcircled{2}$ TO $\textcircled{7}$ IN DA-1 REFERENCE MODULE.
 5. K2 INCLUDED ONLY IN REFERENCE MODULES.
 6. R12 INCLUDED ONLY IN ONE DA-2 OR DA-3 REFERENCE MODULE.
 7. CONNECTION FROM $\textcircled{3}$ TO $\textcircled{6}$ IN DA-1 REFERENCE MODULE AND ALL DA-1 NON-REFERENCE MODULE.
 8. CR4 INCLUDED IN ALL REFERENCE MODULES AND ALL DA-1 NON-REFERENCE MODULES.
 9. C1, CR3, L1, R11, R13 INCLUDED ONLY IN LAST NON-REFERENCE MODULE.

TABLE 1 R1

INPUT Z	AM-19 REF	AM-19 NON-REF	PM-19 REF	PM-19 NON-REF
50Ω	59.1	54.5	64.7	59.1
72Ω	94.3	83.0	109.3	94.3
90Ω				

10. CONNECTION FROM \triangle TO $\frac{1}{2}$ IN ALL REFERENCE MODULES.
11. R1 SELECTED FOR INPUT IMPEDANCE (TABLE 1)

REFERENCE LIMITER GROUND (NOTE 10)

Figure 11-3. AM-19 Input Module, Schematic Diagram

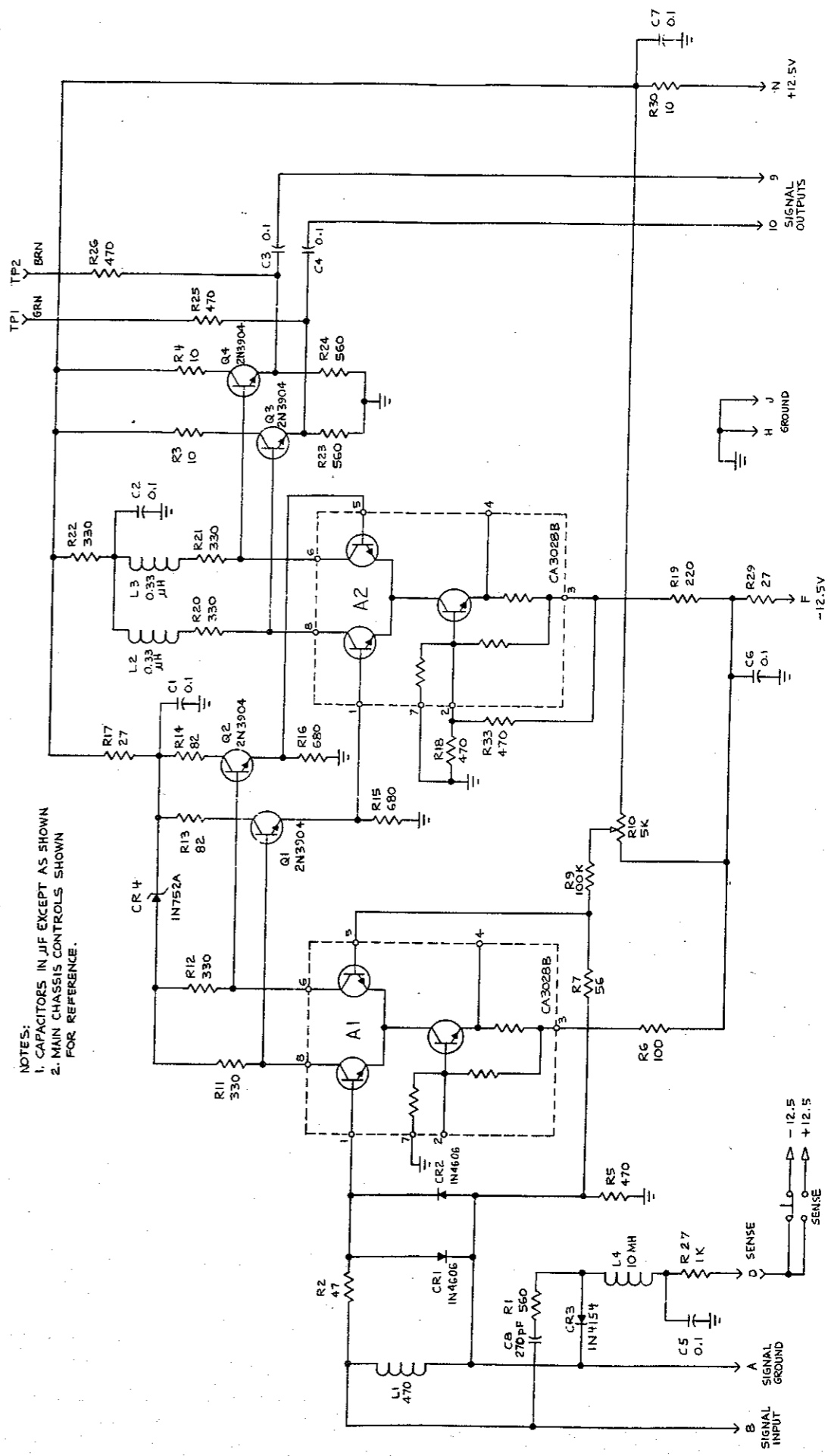

NOTES:
 1. CAPACITORS IN JIF EXCEPT AS SHOWN
 2. MAIN CHASSIS CONTROLS SHOWN FOR REFERENCE.

Figure 11-4. Ilimiter Module, Schematic Diagram

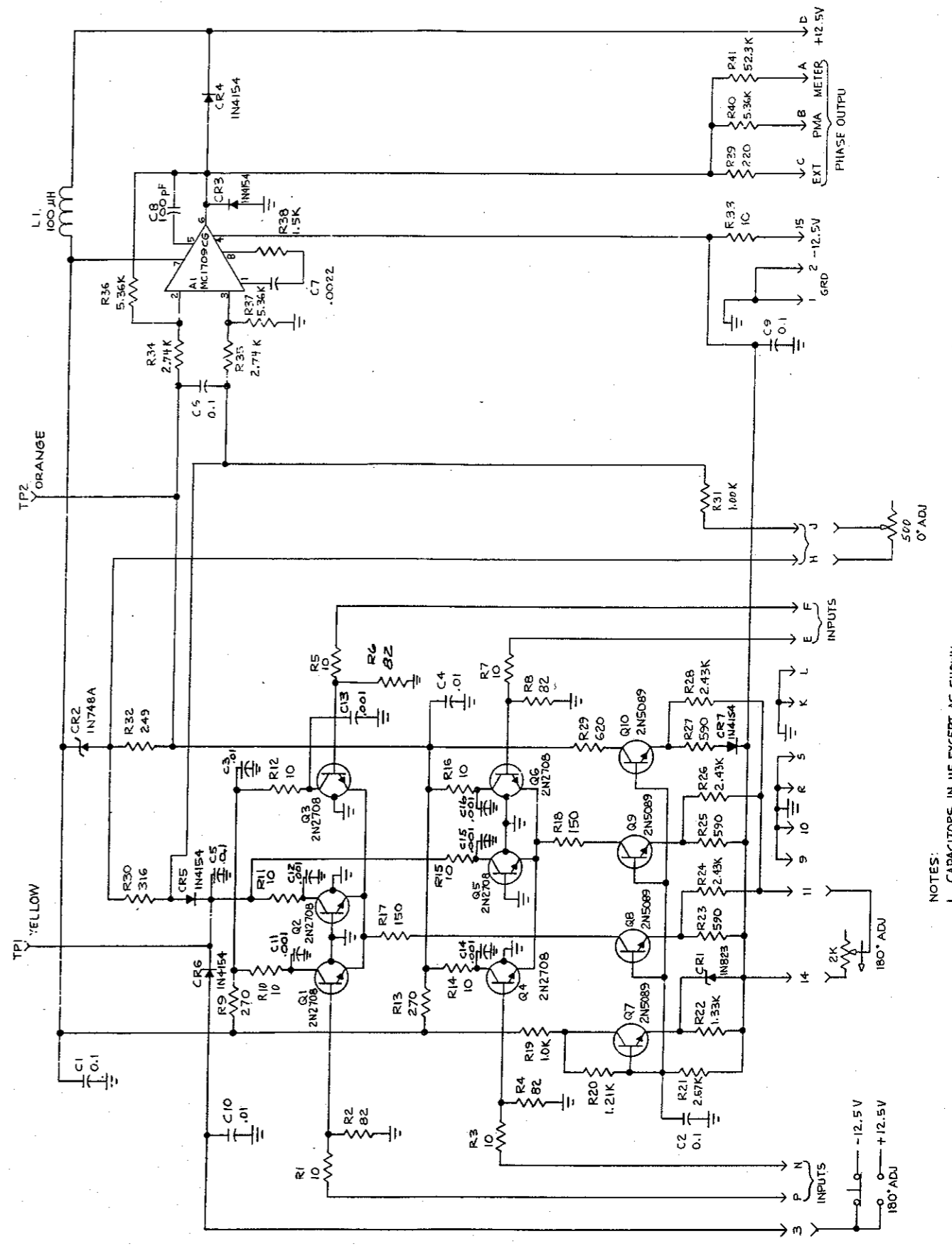

- NOTES:
1. CAPACITORS IN JIF EXCEPT AS SHOWN
 2. MAIN CHASSIS CONTROLS SHOWN FOR REFERENCE

Figure 11-5. Phase Detector Module, Schematic Diagram

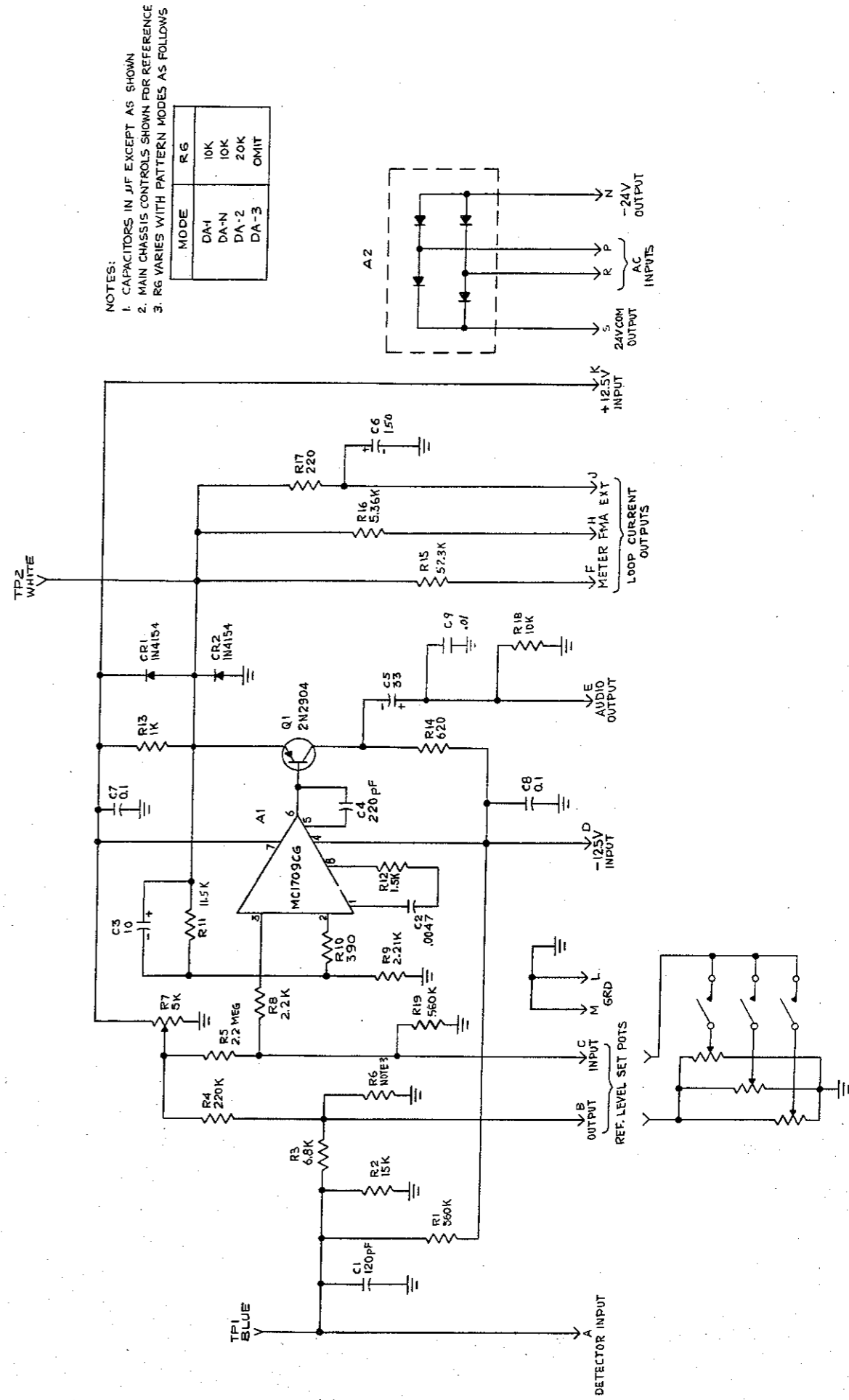
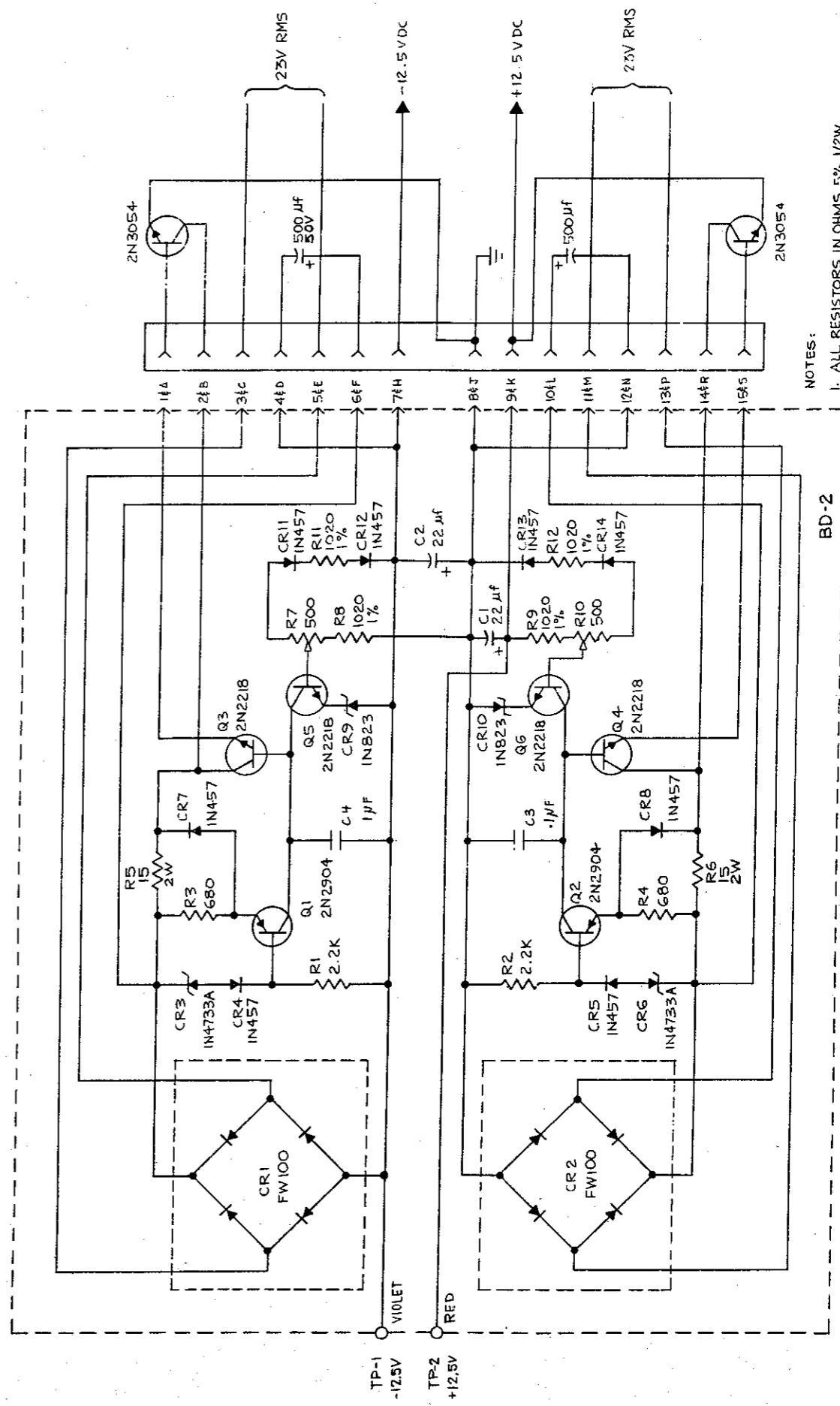

Figure 11-6. Current Meter Module, Schematic Diagram



NOTES:

1. ALL RESISTORS IN OHMS, 5%, 1/2W UNLESS OTHERWISE INDICATED.
2. CHASSIS CONNECTOR AND ASSOCIATED COMPONENTS SHOWN FOR REFERENCE.

Figure 11-7. Power Regulator Module, Schematic Diagram

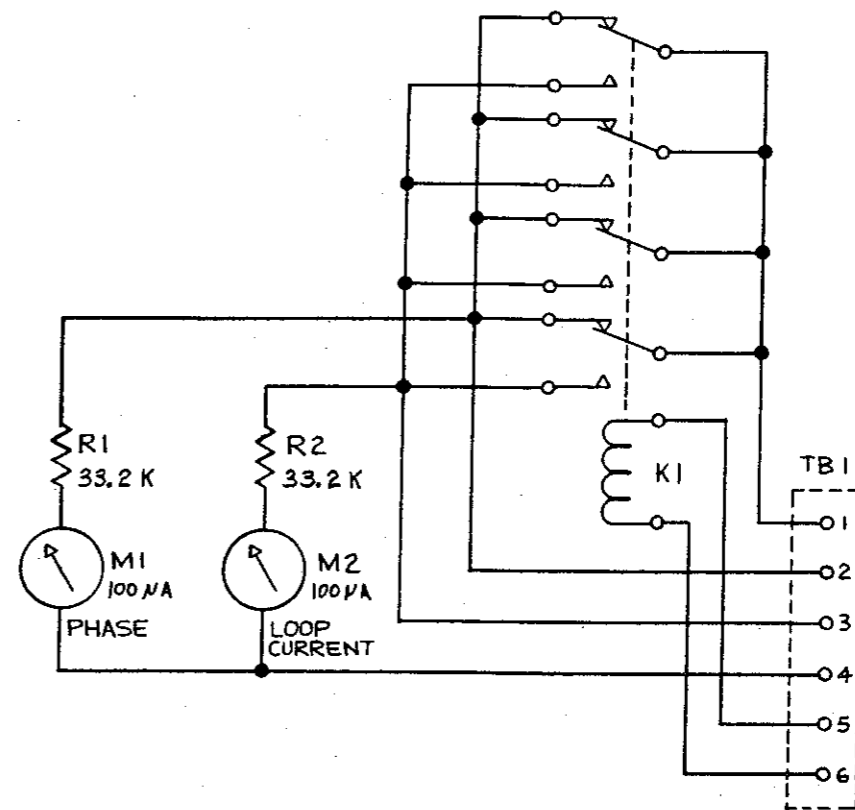

Figure 11-13. Remote Metering Panel, RMP-19, Schematic Diagram

NOTES:

1. R.S.A. RELAYS, POTTER & BRUMFIELD "KHP" SERIES OR EQUIV. SELECT COIL VOLTAGE FOR REMOTE CONTROL OR EXTERNAL SUPPLY. USE 24VDC, 650 OHMS WITH AM-19 SUPPLY, AS SHOWN. ALL R.S.A. DIODES "IN5059" OR EQUIV.
2. CONTACT CLOSURES TO (27) AS SHOWN FOR INDEPENDENT LOCAL-REMOTE OPERATION; CONTACT CLOSURES TO (24) GROUND FOR REMOTE OVERRIDE OPERATION. SEE PARA 3.6.1.
3. USE DIRECT CONNECTION TO METERS FOR SYSTEMS PROVIDING MULTIPLE 100 MICROAMPERE OUTPUTS.
4. SEE RMP-19D(210) MANUAL FOR INTERFACE WITH REMOTE CONTROL STUDIO UNIT.
5. DAY-NIGHT-CRIT HRS CONTACTS ASSOCIATED WITH PATTERN SWITCHING EQUIP.
6. METERING INPUT LOADING: 5K OHMS MIN., AM-19 (204).
10K OHMS MIN., AM-19D (210).

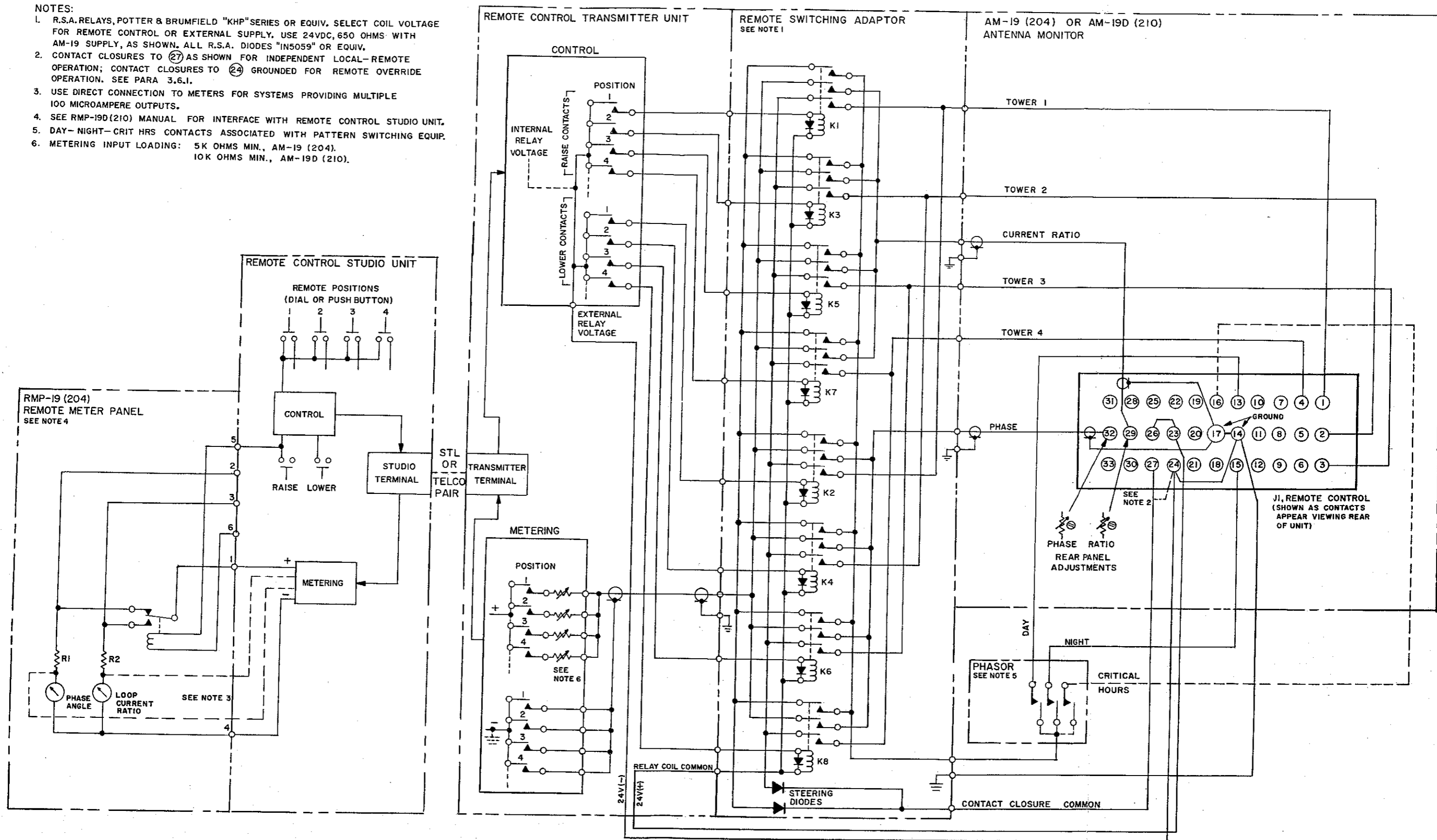

FIGURE II-14. FUNCTIONAL DIAGRAM
TYPICAL REMOTE INSTALLATION

POTOMAC INSTRUMENTS, INC.

Silver Spring, MD.

SUPPLEMENT TO INSTRUCTION MANUAL

TYPE 19 ANTENNA MONITOR SYSTEM
AM-19D(210)

This supplement contains the additions and changes to the Type 19 Instruction Manual which are necessary to cover the AM-19D(210) Antenna Monitor. All sections of the manual applicable to the AM-19 are also applicable to the AM-19D.

SECTION 1 GENERAL DESCRIPTION

The AM-19D (digital) Antenna Monitor consists basically of the AM-19 Monitor with the PHASE ANGLE and LOOP CURRENT meters replaced with digital panel meters; the DPMs are engraved PHASE ANGLE and CURRENT RATIO.

The DPM numeric display provides a significant advantage in resolution, repeatability and readability of phase and current ratio readings. Except as noted in this supplement, the features, performance and operation of the standard and "D" version monitors are the same.

Performance Specifications, AM-19D

Numeric Display:	4 digit LED, 00.0 to 199.9, overrange blanking.
Frequency Range:	540 KHz to 1600 KHz
Phase Angle Range:	00.0° to 180.0°, leading or lagging angles.
Phase Angle Accuracy:	1.0°
Phase Angle Repeatability:*	0.3°
Phase Angle Resolution:	0.1°
Sense Deflection:	+4° nominal for leading angles.
Current Ratio Range:#	05.0% to 199.9%
Current Ratio Accuracy:#	1.0% (20% to 110%), 2.0% (10% to 190%).
Current Ratio Repeatability:*#	0.4% (20% to 190%).
Current Ratio Resolution:#	0.1%, limited by carrier shift with modulation.
RF Input Impedance:	50 or 72 ohms as specified.
RF Input Level Range:	0.5 Vrms to 20 Vrms.
Minimum Input for Reference Tower:	2 Vrms for 100% loop current reference.
Maximum Towers and Patterns:	Up to 12 towers, DA-1 (DA-N, DA-D), DA-2, or DA-3.
Outputs Phase:	0 to 5 V DC for 0 to 180°, adjustable, 10K ohms min.
Loop Current:	0 to 6.5 V DC for 0 to 190%, adjustable, 10K ohms min.
Audio:	0.4 Vrms, 50 Hz to 15 KHz -1 db, 1% THD, 600 ohms nom.
Remote Control Relays:	Isolated or grounded contact closures.
Line Input Power:	105 to 125 V AC, 60 Hz, 62 Volt-amps.
Operating Environment:	+10° C (50° F) to +40° C (104° F), 0 to 95% RH.
Dimensions:	19" rack mounting, 7" high, 12-3/4" behind panel.
Paint Color:	Fed. Std. 595-26555 (other colors special order).

*Long term repeatability with proper calibration, based on factory test data.

#Expressed as percent of reference tower current which is set to 100.0%.

SECTION 9 MAINTENANCE

Delete subsection 9.7 entirely and substitute the following:

9.7 Digital Panel Meters

9.7.1 DPM ZERO Adjustment

The DPM ZERO potentiometer is factory adjusted. Although a small drift may occur in the ZERO setting due to component aging, the offset is normally compensated with the phase and ratio calibration controls. However, if the DPM linearity or stability is questioned, the ZERO setting can be easily checked or adjusted as follows:

1. Allow monitor to reach operating temperature.
2. With power on, remove top cover and remove Phase Detector module (yellow and orange test points).
3. Adjust ZERO potentiometer through small hole in PHASE ANGLE bezel for a reading of 00.0 with the (-) sign off.
4. Replace Phase Detector module and remove Current Meter module (blue and white test points).
5. Adjust ZERO potentiometer through small hole in CURRENT RATIO bezel for a reading of 00.0 with the (-) sign off.
6. Replace Current Meter module and top cover.

9.7.2 DPM Service

Because of the extensive use of LSI (large scale integration) techniques, the digital panel meters are not considered field serviceable. However, the DPMs can be easily removed from the chassis and returned to Potomac Instruments for repair or replacement. To remove either DPM:

1. Turn cable clamp CCW and unplug DPM cable from chassis.
2. Loosen the two screws pressing into recesses in back of panel about 3 turns CCW.
3. Loosen the two screws pressing into recesses in bar attached to DPM flange, so screws clear bar.
4. Slide DPM up and out of chassis.
5. Reverse process to re-install DPM.

The antenna monitor can be operated with one or both DPMs disconnected.

SECTION 12 DIGITAL ANTENNA MONITOR AM-19D(210) - SUPPLEMENT

POTOMAC INSTRUMENTS, INC.

Silver Spring, MD.

SUPPLEMENT TO INSTRUCTION MANUAL

TYPE 19 ANTENNA MONITOR SYSTEM
AM-19D(210)

This supplement contains the additions and changes to the Type 19 Instruction Manual which are necessary to cover the AM-19D(210) Antenna Monitor. All sections of the manual applicable to the AM-19 are also applicable to the AM-19D.

SECTION 1 GENERAL DESCRIPTION

The AM-19D (digital) Antenna Monitor consists basically of the AM-19 Monitor with the PHASE ANGLE and LOOP CURRENT meters replaced with digital panel meters; the DPMs are engraved PHASE ANGLE and CURRENT RATIO.

The DPM numeric display provides a significant advantage in resolution, repeatability and readability of phase and current ratio readings. Except as noted in this supplement, the features, performance and operation of the standard and "D" version monitors are the same.

Performance Specifications, AM-19D

Numeric Display:	4 digit LED, 00.0 to 199.9, overrange blanking.
Frequency Range:	540 KHz to 1600 KHz
Phase Angle Range:	00.0° to 180.0°, leading or lagging angles.
Phase Angle Accuracy:	1.0°
Phase Angle Repeatability:*	0.3°
Phase Angle Resolution:	0.1°
Sense Deflection:	+4° nominal for leading angles.
Current Ratio Range:#	05.0% to 199.9%
Current Ratio Accuracy:#	1.0% (20% to 110%), 2.0% (10% to 190%).
Current Ratio Repeatability:*#	0.4% (20% to 190%).
Current Ratio Resolution:#	0.1%, limited by carrier shift with modulation.
RF Input Impedance:	50 or 72 ohms as specified.
RF Input Level Range:	0.5 Vrms to 20 Vrms.
Minimum Input for Reference Tower:	2 Vrms for 100% loop current reference.
Maximum Towers and Patterns:	Up to 12 towers, DA-1 (DA-N, DA-D), DA-2, or DA-3.
Outputs	
Phase:	0 to 5 V DC for 0 to 180°, adjustable, 10K ohms min.
Loop Current:	0 to 6.5 V DC for 0 to 190%, adjustable, 10K ohms min.
Audio:	0.4 Vrms, 50 Hz to 15 KHz -1 db, 1% THD, 600 ohms nom.
Remote Control Relays:	Isolated or grounded contact closures.
Line Input Power:	105 to 125 V AC, 60 Hz, 62 Volt-amps.
Operating Environment:	+10° C (50° F) to +40° C (104° F), 0 to 95% RH.
Dimensions:	19" rack mounting, 7" high, 12-3/4" behind panel.
Paint Color:	Fed. Std. 595-26555 (other colors special order).

Long term repeatability with proper calibration, based on factory test data.
Expressed as percent of reference tower current which is set to 100.0%.

SECTION 3 INSTALLATION

3.3 Mounting

Because much smaller parameter changes are resolved with the numeric display, ambient temperature conditions require more consideration with the AM-19D. The specified air temperature maximum of 40° C (104° F) should not be exceeded near any chassis surface. Also, at least 1 inch clearance should be provided between adjacent equipment or other obstructions, and the top and bottom covers of the monitor, to allow air to circulate up through the chassis. For maximum stability of readings, variations in temperature should be limited to about 15° C (27° F).

SECTION 4 CALIBRATION AND OPERATION

All references to meter indications should be interpreted as the appropriate DPM display. Also, for specific readings, include a 0 digit to the right of the decimal point; for example, 0° = 00.0°, 180° = 180.0° and 100% = 100.0%. A (-) sign to the left of a reading indicates an improper adjustment or malfunction.

4.1.1 Initial Turn-on: Delete Step 2. Also change NOTE to allow at least 60 minutes warm-up before calibrating monitor.

4.1.4 Current Ratio Calibration: Add the following NOTE:

The numeric display will blank (all numerals off, decimal point on) for readings over 199.9. If blanking occurs, rotate the appropriate (DAY or NIGHT) LOOP REFERENCE potentiometer CCW until the display returns.

4.1.4 Step 3, second paragraph: Change 110% to 199.9%.

4.2.4 Current Ratio Measurements: Add the following NOTE:

Fluctuation in the RATIO readings are caused by carrier level shift associated with asymmetrical modulation. This effect is normal and will depend on the design and adjustment of the transmitter and antenna system and the degree of audio processing. Consistent current ratio logs are obtained by taking readings during modulation lulls which frequently occur during most programs.

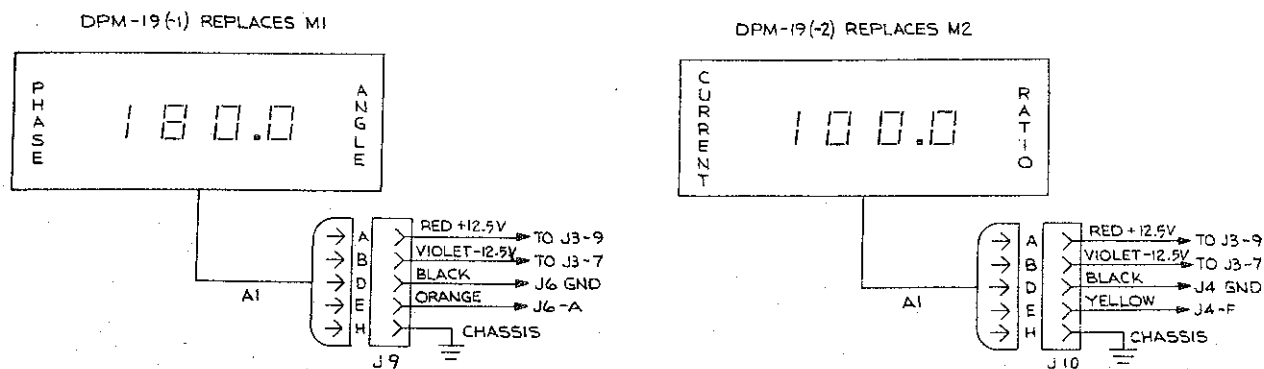

FIGURE A

SECTION 9 MAINTENANCE

Delete subsection 9.7 entirely and substitute the following:

9.7 Digital Panel Meters

9.7.1 DPM ZERO Adjustment

The DPM ZERO potentiometer is factory adjusted. Although a small drift may occur in the ZERO setting due to component aging, the offset is normally compensated with the phase and ratio calibration controls. However, if the DPM linearity or stability is questioned, the ZERO setting can be easily checked or adjusted as follows:

1. Allow monitor to reach operating temperature.
2. With power on, remove top cover and remove Phase Detector module (yellow and orange test points).
3. Adjust ZERO potentiometer through small hole in PHASE ANGLE bezel for a reading of 00.0 with the (-) sign off.
4. Replace Phase Detector module and remove Current Meter module (blue and white test points).
5. Adjust ZERO potentiometer through small hole in CURRENT RATIO bezel for a reading of 00.0 with the (-) sign off.
6. Replace Current Meter module and top cover.

9.7.2 DPM Service

Because of the extensive use of ISI (large scale integration) techniques, the digital panel meters are not considered field serviceable. However, the DPMS can be easily removed from the chassis and returned to Potomac Instruments for repair or replacement. To remove either DPM:

1. Turn cable clamp CCW and unplug DPM cable from chassis.
2. Loosen the two screws pressing into recesses in back of panel about 3 turns CCW.
3. Loosen the two screws pressing into recesses in bar attached to DPM flange, so screws clear bar.
4. Slide DPM up and out of chassis.
5. Reverse process to re-install DPM.

The antenna monitor can be operated with one or both DPMS disconnected.

SECTION 10 and SECTION 11

The following changes are made to the Replaceable Parts Lists and Schematic Diagrams:

Table 10-2 and Figure 11-2, Main Chassis

Add DPM connections to Figure 11-2 as shown in Figure A.

Change C4 to	Capacitor, electrolytic 1500uf, -10% +100%, 50V	Mallory WPO68 or equal
Add J9, 10	Connector, socket, 5 contact	Amphenol, 126-218 or equal
Change M1 to	Digital Panel Meter PHASE ANGLE, 00.0-180.0	Potomac Instruments DPM-19(-1)
Change M2 to	Digital Panel Meter CURRENT RATIO, 00.0-199.9	Potomac Instruments DPM-19(-2)
Change Q2 to	Transistor, silicon, PNP	RCA, 2N6261

Table 10-5 and Figure 11-5, Phase Detector Module

Change R34 and R35 to	Resistor, metal film, 2.67K, 1%, $\frac{1}{4}$ w	RN65C2671F
Change R41 to	Resistor, composition, 220 ohms, 5%, $\frac{1}{4}$ w	RCO7GF221J

Table 10-6 and Figure 11-6, Current Meter Module

Change R11 to	Resistor, metal film, 10.0K, 1%, $\frac{1}{4}$ w	RN65C1002F
Change R13 to	Resistor, composition, 750 ohms, 5%, $\frac{1}{2}$ w	RC20GF751J
Change R15 to	Resistor, composition, 220 ohms, 5%, $\frac{1}{4}$ w	RCO7GF221J
Change R17 to	Resistor, metal film, 1.00K, 1%, $\frac{1}{8}$ w	RN60C1001F

Table 10-7 and Figure 11-7, Power Regulator Module

Change CR2 to	Rectifier, silicon, bridge	Mallory, FWLC-100
Change R6 to	Resistor, wire-wound, 4 ohms, 10%, 8w	Ohmite 1503

Add heat dissipating fin, Wakefield No. 207-AB, to Q4.